



上海梁瑾机电设备有限公司
Shanghai Liangjin Electrical Equipment Co., Ltd

紫光 MS 电机性能及选型尺寸参数

型式 / TYPE



部件分解图 / PARTS DIAGRAM

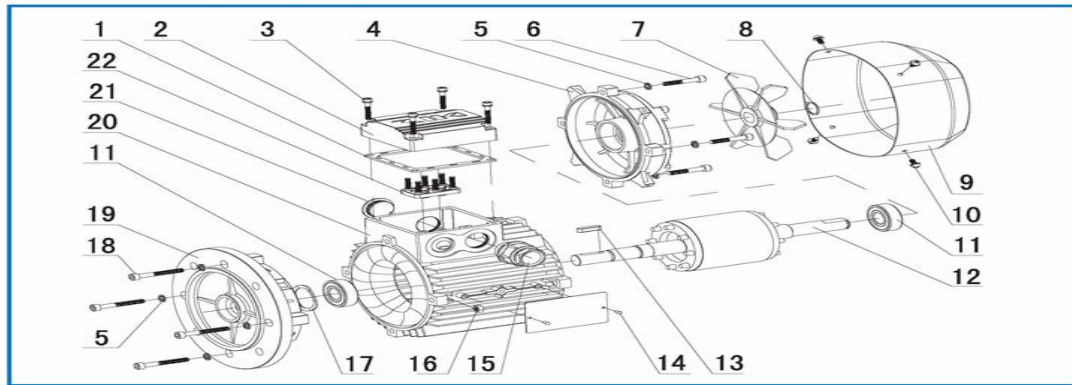

代号指示 / PRODUCT CODE

系列代号 SERIES CODE	MS	三相异步电动机	THREE PHASE ASYNCHRONOUS MOTORS
机座号 FRAME SIZE	56	56 机座	FRAME SIZE 56
	63	63 机座	FRAME SIZE 63
	71	71 机座	FRAME SIZE 71
	80	80 机座	FRAME SIZE 80
	90	90 机座	FRAME SIZE 90
	100	100 机座	FRAME SIZE 100
	112	112 机座	FRAME SIZE 112
	132	132 机座	FRAME SIZE 132
铁芯规格 SPEC. OF IRON CORE	1	1#长度规格	NO.1 LENGTH SPEC
	2	2#长度规格	NO.2 LENGTH SPEC
	3	3#长度规格	NO.3 LENGTH SPEC
电机极数 POLES	2	2极	2 POLES
	4	4极	4 POLES
	6	6极	6 POLES

产品标注 / PRODUCT NOTES

电机产品标注按以下规则标注：系列代号+机座号+铁芯长度规格号+电机极数+安装形式。

例：MS 71 24 B3
MS 90L-2 B5

The marking principle for Motor products is following:

Series Code + Frame Size + Spec. of Iron Core + Poles + Mounting Position.

For example: MS 71 24 B3
MS 90L-2 B5

总体简介 /GENERAL INTRODUCTION

• 结构特点 /STRUCTURE AND FEATURES

- 从 0.06KW-7.5KW的功率等级覆盖范围,8种机座规格。
 - 接线座与机体整体铝合金压铸结构,密封性好,完全符合IP54、IP55的外壳防护等级标准。
 - 增强散热筋设计,使机组具备更强的冷却能力。在恶劣的工作环境下维持电机良好的运行性能。
 - 精确的动平衡校正及专用的低噪声轴承,使电机运行更加平稳、静音。
 - 提供B级、F级绝缘等级制造。
 - 预设的出轴密封装置,与变频器、减速机配套联接时,密封更可靠安全。
 - 符合IEC尺寸标准及IM国际安装结构方式,具备优良的互换性。
- The grade coverage of the power is from 0.06kw to 7.5kw and there are 8 frames specification.
-The Aluminum alloy casting whole structure, good sealing performance. And meet the standard of IP54, IP55 for the outside shell protection.
-Heat sink design for cooling provides great surface area and high thermal capacity, so that the motors can work well in the very terrible operating environment.
-Precise dynamic balance compensation and low-noise bearings, make the motor running more smoothly and quietly.
-With B or F insulation classes.
-When the preset sealing device of the out shaft is connected with the inverter and the reducer, the sealing will be more safe.
-There is the superior interchangeability between the IEC size standard and the IM mounted form.

• 主要材料 /MAIN MATERIAL

- 外壳: 铝合金
 - 轴: 调质处理的40Cr钢
 - 电磁线: 聚酯QZ-2; 聚酰亚胺QY-2
 - 硅钢片: DW470-600
 - 轴承: C&U; NSK; NTN; SKF
- Outside shell: Aluminum alloy
-Shaft: 40Cr steel heat refined
-Electromagnetic wire: Poly-QZ-2; Polyimide QY-2
-Si steel plate: DW470-600
-Bearing: C&U; NSK; NTN; SKF

• 涂漆 /PAINTING

- RAL9006 银色
- RAL5010 蓝色
- RAL9006 silver
- RAL5010 blue

• 统一标准 /CONSOLIDATED STANDARD

所有通用电机执行统一的制作标准:

- 电机尺寸及功率等级: GB4772.1; IEC60072
 - 电气规范: GB755; IEC60034-1;
 - 结构及安装型式: GB997; IEC60034-7;
 - 外壳防护等级: GB4942.1; IEC60034-5
 - 冷却方式: GB/T1993; IEC60034-6
- All general-purpose motors perform the following manufacture standard.
- Motor dimension and power grade: GB4772.1.1; IEC60072
- Electric criterion: GB755; IEC60034-1
- Structure and mounting position: GB997; IEC60034-7
- outside shell protection grade: GB4942.1; IEC60034-5
- Cooling mode: GB/T1993; IEC60034-6

电机的工作过程 /OPERATION COURSE OF MOTOR

•工作原理 /OPERATION PRINCIPLE

交流异步电机是将电能转换为旋转机械能的部件单元。当电机接通电源时，电机定子绕组即产生以固定转速 n_0 旋转的磁场。 n_0 即为电机的同步转速，它的值仅与电源的频率(f)及电机绕组的构造极数(P)有关，即：

AC asynchronous motor is a unit that transfers electric energy into mechanical energy. When we supply the power to it, electric motor's stator winding will create a rotational magnetic with fixed speed rotary speed n_0 . The speed n_0 is same as the synchronous speed of the electric motor, and its value is related with the frequency of power and the structure poles of motor winding, that is:

$$n_0 = \frac{60 \times f}{p} \quad (\text{转/分钟}) (\text{r/min})$$

旋转的磁场使电机转子产生感应电流，从而使电机转子受到电磁力矩的牵引而带动负载旋转。只要转子转速与磁场转速存在差异，电机转子上就保持有电磁转矩的作用，并且差异越大转子上产生的电磁转矩也越大。电机输出转速 n 与同步转速(n_0)的差异程度将以转差率 S 表示：

Rotational magnetic make electric motor rotor create faradism torque, which rotate the load. As long as the speed difference existed between the rotor rotation speed and magnetic field rotation speed, the rotor of electric motor will keep the magnetic torque and more difference will create more magnetic torque. The difference degree of the electric motor's output rotate speed n and the synchronous rotate speed n_0 will be shown as rotation difference rate S :

$$S = \frac{n_0 - n}{n_0}$$

下图中曲线(M)表明电机转子的输出转矩与转速的关系，表征电机的输出机械特性。它与负载曲线(M_L)相交于一点，该点即为电机带动负载稳定运行时的工作点，在工作点时电机上的输出转矩与负载转矩相等。

In following picture, curve (M) indicates the relation of electric motor output torque and rotational speed of rotor, as token of the output mechanical characteristic of the electric motor. It cross load curve (M_L), this cross point is namely the operating point which the electrical motor can drives loads steadily. And at this point, the output torque on the electrical motor is equal to load torque.

•主要转矩指标 /MAIN TORQUE INDEX

由图示曲线(M)可知，在电机力矩特性曲线中对实际应用有影响的力矩指标有：

You can learn from curve (M) of picture: the following torque indexes of electric motor influence practice application in the torque characteristic curve of electric motor:

M_{st} : 启动转矩。电机在通电启动瞬间(转速为零)时的输出转矩，表示电机带负载启动的能力。

M_{St} : Start torque. Output torque is generated when electrical motor start up (rotational speed is zero) shows the start load capacity of electric motor.

M_{max} : 最大转矩。电机转矩特性曲线中从高速到低速方向的第一个峰点最大值。表示电机在稳定工作后，抵抗负载变化的过载能力。

M_{max} : The max. torque. It is the first peak from high speed to low speed direction in the torque characteristic curve of electric motor that shows the electric motor ability resists the overload capacity for load change in steadily operation.

M_{min} : 最小转矩。在电机转矩曲线中，从零转速开始到最大转矩处的最小值。它与启动转矩 M_s 一起表示电机带动负载进入稳定工作点的能力。以下电机性能参数表中给出本公司制造的各种电机启动转矩与额定转矩的比值(M_{st}/M_N)、最大转矩与额定转矩的比值(M_{max}/M_N)。

M_{min} : Minimum torque. Minimum torque is the minimum value among electrical motor torque curve from start to the maximum torque. Together with start torque M_s , it indicate the ability of electrical motor drives load steadily.

•工作点 /OPERATION POINT

电机带负载工作到稳定状态后，电机的输出转矩与负载转矩保持动态的平衡，电机的工作转速也相应保持在该点的转速值 n_1 上。负载发生加大或减轻波动时，转速 n_1 也相应降低或增加而使电机的输出力矩加大或减小使之与负载的变化得以平衡。

Electric motor operates with load steadily, the output torque and load torque of the electric motor keep in dynamic balance, the operation rotational speed of the electric motor keeps on the rotational speed value n_1 correspondingly. When the Load become bigger or smaller, the rotational speed n_1 corresponding reduce or increase and make output torque of electric motor increase or decrease in order to make it change accordingly.

理论上，电机的工作点只能位于特性曲线中最大转矩 (M_{max}) 右侧 ($n'--n_0$ 之间) 的曲线段。因为只有在这一段电机才有自动与负载波动平衡的能力。

In theory, the operation point of the electric motor will only lie in the right side ($n' n_0$) of the max. torque (M_{max}) in the characteristic curve. Cause during only this section, the electric motor has automatic adjustment ability of the balance with the load change.

每型电机规定了一具体的额定输出功率 (P_N) 及额定输出力矩 (M_N)，在使用时电机工作点不应超过该型电机规定的额定点 (M_N)，否则电机有损坏的可能。

Every type of electric motor has stipulated a rated power (P_N) and rated torque (M_N), electric motor operating point shouldn't be over the rated point (M_N) while using, otherwise the electric motor will possible damage.

•电机的启动时间 /THE START TIME FOR MOTORS

电机带动负载从零转速到达稳定的工作点转速 n_L 的过程即为电机的启动过程。电机的启动时间与旋转系统的总转动惯量 (J_{tot})、电机输出电磁转矩 (M)、负载阻力矩 (M_L) 有关。

The start-up course of electric motor is the course of Electric motor drive load from zero rotational speed to the rotational speed n_L (steady operating point). The starting time of the electric motor is related with total rotatory inertia (J_{tot}) of the rotatory system, the electric motor output electromagnetic torque (M), the load drag torque (M_L).

M 和 M_L 的差值即为推动系统的加速转矩 (M_a) :

The difference of M and M_L , equal to the accelerating torque (M_a) of drive system:

$$M_a = M - M_L = f_1(n) - f_2(n) = \psi(n)$$

电机的启动时间 (t_{st}) 可以以如下公式表示:

The start time (t_{st}) of electric motor shows as following formula:

$$t_{st} = \frac{\pi}{30} \times J_{tot} \times \int_0^{n_L} \frac{1}{\psi(n)} \times d(n)$$

t_{st} --电机启动时间，秒； /Start time of electric motor, second.

J_{tot} --机组的总转动惯量，Kg·m²； /Total rotational inertia

n_L --电机的负载速度，转/分钟； /The speed of electric motor with load, rpm

M : 电机输出转矩转速曲线 / M : motor output rotatory torque rotatory speed curve

M_a : 电机加速力矩曲线 / M_a : motors accelerated torque curve

M_L : 负载力矩曲线 / M_L : load torque curve

公司名称：上海梁瑾机电设备有限公司

联系人：杨奇 13661695091

QQ:1914222621 570998234

电话:021-37652287 传真:021-57872573

网址: <http://www.zik-rhg.com> www.shhgjdqi.com

地址：中国上海上海市松江区茜浦路 850 弄 33 号

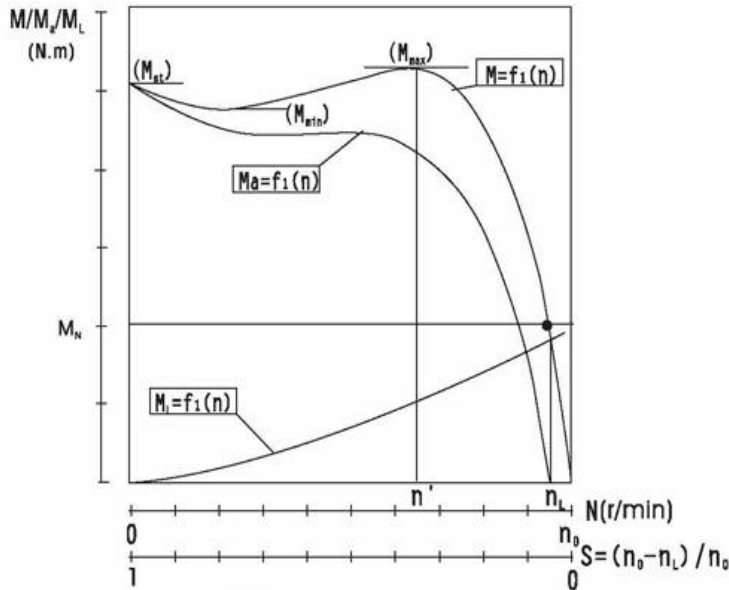

• 电机的运行特性 /OPERATION CHARACTERISTIC OF THE ELECTRIC MOTOR

在带负载工作运行时，电机的实际输出功率 (P_{out}) 的大小恒等于实际负载的需求功率。负载的加重或减轻相应使电机输出功率增加或减少。电机在不同工作点时的工作转速 (n_L)、转矩 (M)、输出功率

(P_{out})、功率因数 ($\cos\phi$)、效率 (η)、电流 (I) 等将随着负载的变化而变化 (如下图所示)，这种变化是由电机的运行特性所决定的。

When running with load, the actual output power (P_{out}) of electric motor equal to demanded power of actual load identically. Increase or decrease of load will make the output power of the electric motor increase or decrease correspondingly. Operation rotational speed in different operating points of the electric motor (n_L), torque (M), output power (P_{out}), power factor ($\cos\phi$), efficiency (η) electric current (I), etc. will change with load change, this kind of change is determined by operation characteristic of the electric motor.

$n-P_{out}$ 特性：从空载到加载，随着电机输出功率的增大，电机转速 (n) 稍有下降。一般电机在额定点 ($n=n_N, P_{out}=P_N$) 时的转差率 (S) 约为：0.06 左右。

$n-P_{out}$ characteristic: From no load to increase load, with output power of electric motor increasing, the rotational speed of the electric motor (n) slightly drops. The rate of rotational difference (S) is about 0.06 when the general electric motor works at rated points ($n=n_N, P_{out}=P_N$).

$M, I-P_{out}$ 特性：电机的转矩随负载的增大而增大。

$M, I-P_{out}$ characteristic: The torque of the electric motor increases when the load increases.

$\eta, \cos\phi-P_{out}$ 特性：轻载时电机的效率 (η) 及功率因数 ($\cos\phi$) 很低，当负载增大到50%额定值以上时， η 值和 $\cos\phi$ 值迅速增大并保持基本稳定。

$\eta, \cos\phi-P_{out}$ characteristic: Efficiency (η) and power factor ($\cos\phi$) of electric motor are very low with light load; when the load increase to over 50% of the rated load, η value and $\cos\phi$ value will increase rapidly and become steady.

$n-P_{out}$: 转速特性 / NP_{out} : Rotate speed characteristic

$I-P_{out}$: 电流特性 / IP_{out} : Electrical current characteristic

$\eta-P_{out}$: 效率特性 / ηP_{out} : Efficiency characteristic

$\cos\phi-P_{out}$: 功率因数特性 / $\cos\phi P_{out}$: Power factor characteristic

$M-P_{out}$: 转矩特性 / MP_{out} : Torque characteristic

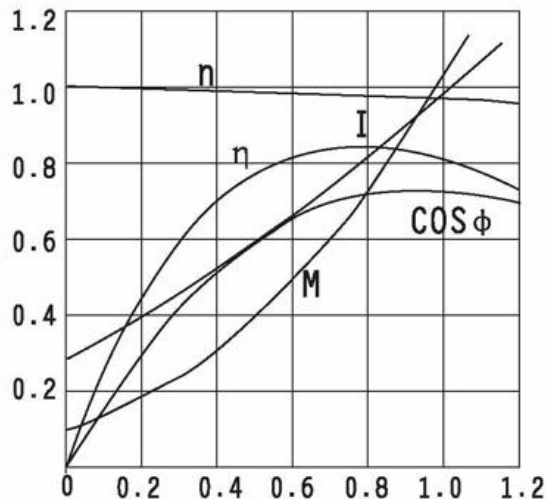

应用规范 /APPLICATION CRITERION

• 定额工作制 /RATED WORK SYSTEM

工作制是电机承受负载情况的说明，是电机设计和使用选择的基础。一般用途的电机，其定额应为最大连续定额，并能按 S1 工作制运行。本公司制造的电机均为按 S1 工作制运行的最大连续定额提供技术性能参数。

The work system is the explanation of an electric motor load status. It is the foundation of design and selection of electric motor. Electric motor for general purpose, its ration should be max. continuous ration, and it can run according to S1 work system. Our company provides the electric motor with technical performance of max. continuous ration according to S1 work system.

连续工作制 (S1) :

电机在恒定负载下的运行，运行时间足以达到热稳定。

CONTINUOUS WORK SYSTEM (S1): Electric motor runs with invariable load. Running time is enough to reach the temperature stability.

短时工作制 (S2) :

电机在恒定负载下按给定的时间运行，该时间不足以达到热稳定，随之即断能停转足够时间，使电机再度冷却到环境温度。

SHORT TIME WORK SYSTEM (S2): Electric motor run with invariable load with certain time, but the running time is not enough to reach the temperature stability. Then it stop running with enough time to cool the temperature of electric motor to as the environment temperature once again.

断续周期工作制 (S3) :

电机按一系列相同的工作周期运行，每一周期包括一段恒定负载运行时间和一段断能停转时间。通常以负载持续率 = $N / (N+R) * 100\%$ 加以表征。

INTERVAL PERIODICAL OPERATION SYSTEM (S3): the electric motors will run continually with same operation cycle which include a certain time for operation and certain time for stop. generally its token is load continuance ratio = $n / (n+r) * 100\%$

公司名称: 上海梁瑾机电设备有限公司

联系人: 杨奇 13661695091

QQ:1914222621 570998234

电话:021-37652287 传真:021-57872573

网址: <http://www.zik-rhg.com> www.shhgjdqi.com

地址: 中国上海上海市松江区茜浦路 850 弄 33 号

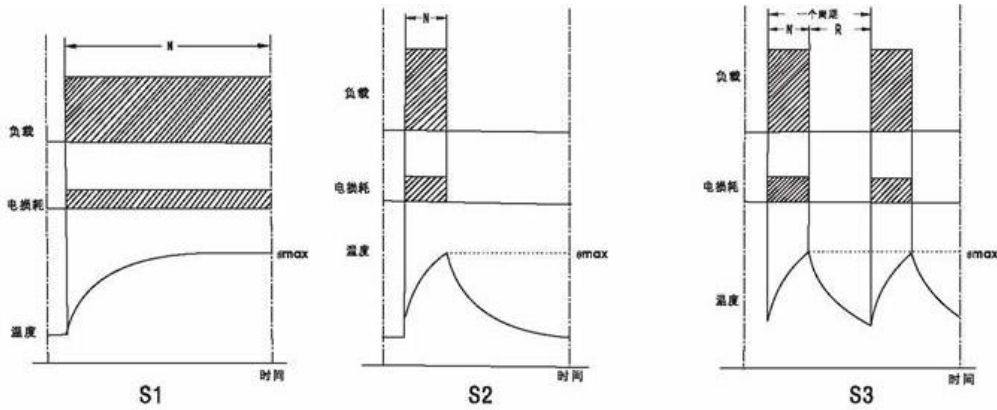

-当电机按S2或S3定额工作制运行时，可按如下图表的修正系数 K 适当递增电机的许可使用功率：

-When electric motors runs under operation system S2 or S3, the allowed applied power can be properly increased according to the modify coefficient as following charts.

• 额定电压和频率 / RATED VOLTAGE AND FREQUENCY

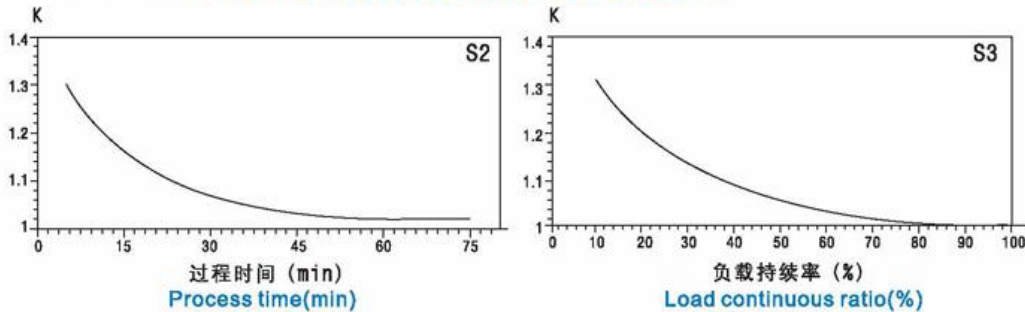

每型电机都规定了其额定的工作电压及频率，并在电机铭牌上标示。在使用电机时，必须保证电源电压、频率与电机规定的额定值相符合。否则，电机的性能指标将得不到有效的保障甚至损坏电机造成危害。在本册技术性能表中列出的电机主要性能指标都是在额定电压及额定频率下的正常运行条件下获得的。

Every type of electric motor was specified with its rated work voltage and frequency and marked on its brand plate. When we use the electric motor, we should supply the correct power voltage, frequency in accordance to the specified rated value of electric motor. Otherwise, the performance of electric motor won't be valid. The main performance index listed in our technical performance table was obtained under the condition of the rated voltage and rated frequency and normal running conditions.

所有电机在电源实际电压偏离额定电压不超过 $\pm 5\%$ ；实际频率偏离不超过额定频率 $\pm 1\%$ 的时候，将能保证正常的功率输出。

All electric motors will work with normal output power when the supplied electric voltage is within 5% more or less from rated voltage and practical frequency is within 1% more or less from rated frequency.

三相电机在额定频率下，可按 Δ 形接线及 Y 形接线同时提供两档额定电压值。电机在该两种接法的额定值下运行将保持完全相同的运行性能。理论上 Y 形接法的额定电压值是 Δ 形接法额定电压值的 $3^{1/2}$ 倍。

3-phase electric motor may provide two type of rated voltage value with Δ -connection and Y connection under the rated frequency. The operation performance of electric motor is same with above 2 connections. In theory, the rated voltage value of Y-connection is $3^{1/2}$ times of the rated voltage value of Δ -connection.

如未特别说明，我们将按中国电源标准提供电机：三相电机 4KW 以下按 Y 形接线 380V/50Hz (Δ 形接线 220V/50Hz) 提供；4KW 以上(包括 4KW)按 Δ 形接线 380V/50Hz 提供；如用户需要其他额定电压及额定频率的电机产品，须向我公司作特别订货。

Without special specification, we will provide electric motors according to China electricity standard: Three phase motor below 4KW will be Y-connection 380V/50HZ (Δ -connection 220V/50HZ), above 4KW(including 4KW) provide with Δ -connection 380V/50HZ; If customer need other rated voltage and frequency, please order with special indication.

-对于三相电机，同时按相同倍数提高或降低电机的额定电压和额定频率是允许的。50Hz的电机将电压提高1.2倍后，可在60Hz的频率下运行，而保持该电机效率(η)、功率因数($\cos\phi$)、转矩(M_N 、 M_{st}/M_N 、 M_{max}/M_N)、绝对转差($n_s - n$)等指标的基本不变，而转速及输出功率将相应提高为原来的1.2倍

-For three phase electric motor, it is allowed to increase or decrease the rated voltage and rated frequency at the same ratio. If we increase the voltage by 1.2 times from 50Hz, the electric motor can be operated with 60Hz frequency and will have the similar index as before like electric motor efficiency (η), power factor ($\cos\phi$), torque (M_N , M_{st}/M_N , M_{max}/M_N) and absolute rotational difference ($n_s - n$) etc, but the rotational speed and output power will increase 1.2 times accordingly.

以下表格中第一栏中列出 50 Hz 的额定工作电压，第二栏中列出与之等效的 60Hz 工作电压，第三栏中列出该额定电压下许可使用的工作电压范围。

The first column of following table indicates the rated operation voltage in 50Hz, and the second column indicates the equivalent operation voltage in 60Hz. In the third column indicates the allowed usable voltage.

标称额定电压/RATED VOLTAGES		许可使用电压 /ALLOWED USABLE VOLTAGES
220/380 50	264/456 60	(209-231) / (360-400) 50Hz; (250-277) / (433-478) 60Hz
230/400 50	277/480 60	(218-241) / (380-420) 50Hz; (264-290) / (456-504) 60Hz
190/330 50	220/380 60	(180-200) / (313-346) 50Hz; (209-231) / (360-400) 60Hz
208/360 50	254/440 60	(197-220) / (342-380) 50Hz; (240-266) / (418-462) 60Hz

-电机的工作电压偏离额定值时，电机的启动转矩 (M_{st})、最小转矩 (M_{min})、最大转矩 (M_{max}) 等将受到影响。如果电机重载工作时，必须注意这种工作电压与输出力矩(M)的变化关系。

-Once the operation voltage of electric motor departure the rated value, it will influence the start torque of electric motor, the minimum torque, and the max. torque and so on. If the electric motor operates with heavy load, we should pay more attention to the related change between operation voltage and output torque.

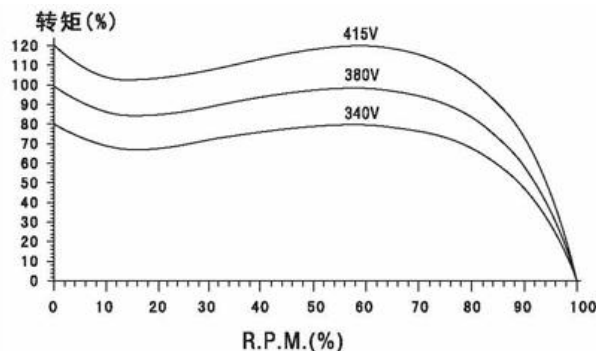

力矩大小近似与电压平方成正比
Torque is nearly direct ratio to voltage's square.

• 运行环境 /OPERATION ENVIRONMENT

电机的标准电气规范是按S1定额工作制；在额定电压、额定频率下；使用环境空气温度不超过40°C、海拔高度不超过1000m的运行条件下给出的。如电机需在超过40°C或海拔高于1000m的工作环境中工作，需按专业经验修正电机的许可使用功率。

The standard electric criterion of electric motor was obtained according the S1 rated operation condition and with rated voltage and rated frequency; Ambient temperature no more than 40°C, altitude below 1000m, etc. If the motors have to be used in the operation conditions like the ambient temperature over 40°C or height of sea level is over 1000m, the usable power of electric motor should be modified by professional experience.

-如环境温度高于40°C时，应按如下表格中的修正系数修正电机的许可使用功率：

-If the ambient temperature is over 40°C, the usable power should be modified according to the modified coefficient as following table.

环境温度 (°C)/AMBIENT TEMPERATURE (°C)	40	45	50	55	60
修正系数 (%) / MODIFIED COEFFICIENT (%)	100	96	92	88	83

-如工作环境海拔高度超过1000m，应按如下表格中的修正系数修正电机的许可使用功率：

-If the altitude for operation is over 1000m, the allowed usable power should be modified according to the modify coefficient as following table.

海拔高度 (M) /ALTITUDE(M)	1000	1500	2000	2500	3000
修正系数 (%) /MODIFIED COEFFICIENT (%)	100	96	92	88	83

• 噪声等级 /NOISE GRADE

电机工作噪声主要由电磁场、轴承和风冷系统产生。而最大的噪声主要由风冷系统的风扇产生。

The noise during the operation of electric motors is created by the magnetic field, the bearings, and the wind cooling system. However mainly the cooling fan of wind cooling system creates the noise.

技术数据表中的噪声数据dB (A)与ISO1680相一致。当电机工作于60Hz时，以上数据约增加3/4dB (A)。

The values of noise in dB (A) shown in the technical data sheets are in accordance to ISO1680. When motors operate at 60Hz, the above values will increase about 3/4 dB (A).

• 温升及绝缘等级 /TEMPERATURE RISE AND ISOLATION GRADE

电机工作时，一方面由于绕组电流及轴承旋转摩擦将使电机产生发热而使电机各部分的温度升高；另一方面电机通过外表向环境冷却介质散发热量。电机温度越高向外散热功能越强，而电机在稳定运行时的发热量是相对恒定的，因此当发热与散热达到平衡后电机各部分的温度将保持恒定。它们与冷却介质的温度差即为该部分的温升。

When electric motor is operating, the rotational friction of bearings and winding current will create heat and rise up the temperature of every part of electric motor; The electric motor will give out the quantity of heat from surface to ambient cooling medium. The electric motors will give out more quantity of heat when the temperature of electric motor is higher. And the generation of quantity of heat will be invariable when the electric motor operates steadily. Then there will be a balance of quantity of heat's generation and giving out. And every part of electric motor will have invariable temperature, and the temperature difference of them and the cooling medium is called temperature rise.

对于电机来说，过高的温度将主要对电机的绕组及轴承造成损害。因此对电机的绕组温升及轴承处的最高温度作出了规定。同时绝缘等级作为表征电机绕组的耐热程度指标，也作出了相应的规定。

For electric motor, too high temperature will do damage mainly to the windings and bearing of the electric motors. So we specify the temperature rise for windings and the highest temperature for the bearings. At the same time, we also specify the heat endurance of the different isolation grade.

本公司的电机绕组按B级或F级绝缘等级制作。并且由于采用了增强散热筋的铝合金外壳，使电机绕组温升大为降低（大部分电机的绕组温升在40--60K之间）。从而确保电机的安全运行。

Our electric motor windings are made in accordance with B or F isolation grade. We adopt the aluminum alloy cases with heat sink design which decrease greatly the temperature rise of electric motor windings (temperature rise of most electric motor windings is between 40-60k), thereby it will ensure the safe running of electric motors.

• 外壳防护等级 /HOUSING PROTECTION LEVEL

电机的外壳防护等级表示电机在以下两个方面的防护能力：

The housing protection level of electric motor indicates 2 protection abilities as following:

- (1) 防止人体接触电机内部带电或转动部分和防止固体异物进入电机内部的能力
- (2) 防止水进入电机内部的能力

1. Prevent body from touching the electriferous inner parts of electric motor and prevent solid eyewinker from entering into the inner of electric motor.

2. Prevent water from entering into the interior of the electric motor.

本公司制造的电机采用接线盒与机体一体压铸，并在外壳所有出轴及接合处均设有密封装置可以达到IP54、IP55的防护等级。（如无特别说明，默认按IP54供货）

The die casting of the terminal box and the housing is a integrative die casting. And there are seal equipments at the all output shafts and joint point in order to reach IP54, IP55 protection grade (default type is IP54 level.)

IP54: 防尘并完全防止人体触及或异物进入电机内部、防任何方向的溅水

IP54: Dustproof and avoid body touching and eyewinker entering into the interior of electric motors, as well as to prevent the spattered water from any direction.

IP55: 防尘并完全防止人体触及或异物进入电机内部、防任何方向的喷水

IP55: Dustproof and avoid body touching and eyewinker entering into the interior of electric motors, as well as to prevent the spattered water from any direction.

三相电机的变频调速 /FREQUENCY INVERTER OF THREE PHASE ELECTRIC MOTOR

通过配置变频器改变三相异步电机的电压及频率，可使三相电机获得一定范围的无级速度调速。理论上电压与频率的变化必须保持一定的关系：

Through inverter, we can change the electric voltage and frequency for three phase asynchronous electric motors, which will adjust electric motors speed stepless.

当 $f < f_N$ 时：电机工作于低速区，能获得低于额定转速的各种转速。为保持电机的输出转矩恒定不变，电压必须与频率作同步线性变化，即 $U/f = U_N/f_N = \text{常数}$ 。

When $f < f_N$: the electric motor operate in low-speed area, and get the various speed will be lower than the rotate speed. To keep the output torque invariable, electric voltage should have synchronous and linear alteration with frequency, that is, $U/f = U_N/f_N = \text{constant}$.

当 $f > f_N$ 时：电机工作于高速区，能获得高于额定转速的各种转速。在高速区电机将作恒功率驱动，且为保持电机过载能力不变，电压与频率须保持 $U/f^{1/2} = U_N/f_N^{1/2} = \text{常数}$ 的变化规律。

When $f > f_N$: electric motor works in high-speed area, the various speed will be faster than the rotate speed. It drives with constant power in the high-speed area, and the change of electric voltage & frequency should obey the rules of $U/f^{1/2} = U_N/f_N^{1/2} = \text{constant}$.

电机在低频段 ($f < f_N$) 工作时，由于工作电压较低，电机定子绕组本身的电压降落将大大影响电机的输出力矩，有时甚至不能带动负载，因此实际应用中往往根据电机定转子漏阻抗 (X) 与定子电阻 (R_s) 的比值 ($Q = X/R_s$) 提升电机的输入电压以作补偿。必须指出，电机空载时 R_s 上负载电流产生的

的压降较少，过深的电压补偿有可能导致磁路饱和，使励磁电流达到不允许的数值。

When electric motor work with low frequency ($f < f_N$), due to the lower voltage, the decreased voltage of rotor winding will reducer the output torque largely. Sometimes it even cannot drive the load. Therefore in practical use, we sometimes raise the input voltage according to the ratio ($Q = X/R_s$) of motor stator rotor leaking impedance (X) and the stator resistance (R_s) as compensation. We must indicate that the voltage of electric motors without load will decrease slightly. Too much increase of voltage compensation will make magnetism route saturated. And the current may be over the allowed value.

电机在高频段 ($f > f_N$) 工作时，由于电机的工作电压超过额定电压是不允许的，因此在实际使用中，随着频率的升高，电机电压往往不会升高，而维持额定电压 U_N 不变。

- 下图表示电机在变频调速时实际的电压与频率关系。

When electric motor work in high frequency ($f > f_N$), the work voltage of electric motor is not allowed to over the rated voltage, therefore, in the practical usage, the voltage of electric motor won't rise up with the frequency rising up but keep the rated voltage U_N . The following picture shows the relationship of practical voltage and frequency of electric motor when we adjust the speed by inverter:

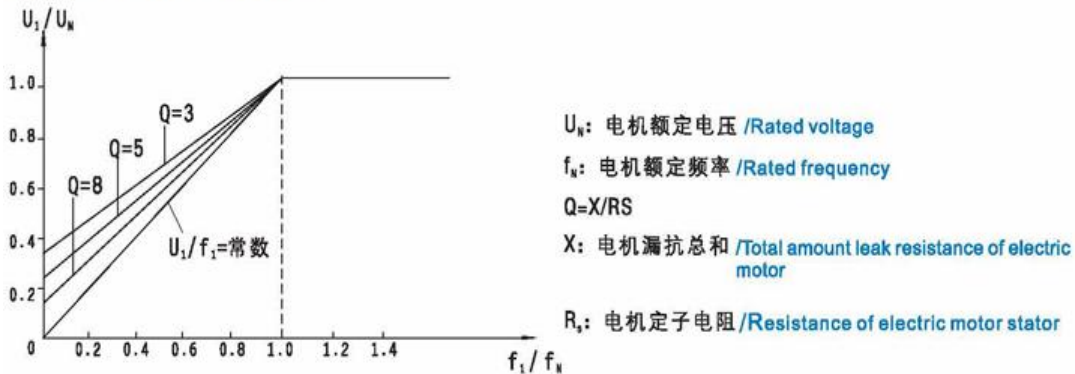

- 下图曲线表示额定频率为 50Hz 的电机，在进行变频调速时的输出转矩转速特性

- The following diagram describes the performance of output torque & speed when a electric motor (with rated frequency 50Hz) adjust the speed by inverter

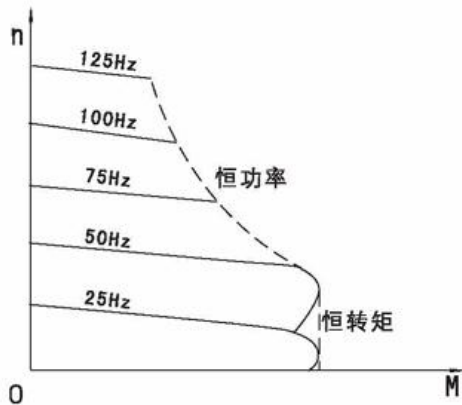

本公司的通用三相电机能够配置变频器进行变频调速操作。在低频工作区工作时，由于电机转速的降低而使电机原有设计的风冷系统的冷却作用降低，电机温升将会上升；在高频区操作时，过高的转速将使冷却风扇消耗更多的功率，并且大大增加电机的运行噪声。另外，由于变频电源的输出电压为高频脉冲，高次谐波成份较多，并会对电机的工作噪声及绕组带来有害的影响。因此我们建议：在进行变频操作时电机应采用较高的绝缘等级（F级），最好加装独立的冷却风扇。

Our series general-purpose three-phase electric motor may realize adjusting speed by frequency adjustment via equipped inverter device. When it works in low frequency operation area, the designed cooling function of wind-cooling system for electric motor will decrease due to the decrease of motor speed, So the temperature of the electric motor will rise up. When the electric motor works in high frequency, over speed will make the cooling fan consume more power and increase the running noise of electric motor. Additionally, owing to the output voltage of changing frequency is high frequency pulse, It will create high syntonic wave. This will bring harmful effect to the operation noise and windings of electric motors. Thereby we advice: electric motor should adopt higher isolation grade- (F class) with separate cooling fan when the electric motor need adjust speed by changing frequency.

特别引起注意的是，过高的频率将使电机铁芯涡流损耗加大，在超过120Hz时，最好采用专用的变频电机。专用的变频电机无论在调速范围及性能等方面都更适合于变频器操作。如配置速度反馈编码器，可与变频器组成性能优良的闭环调速系统。

Please note it specially: too high frequency may enlarge whirlpool wastage of electric rotor core. When the voltage is over 120Hz, it is better to adopt special frequency conversion motors. Special use frequency conversion motors have a better performance in timing scope etc.

下表为本公司技术测试室对部分电机在下限频率变频运行时获取的数据记录，所有参数均在电机达到热平衡状态后取得（V/F：线性；低速转矩提升设置3%）：

The following table was gained by the test of our technical department while motors were running under the different frequency. All parameters are recorded after the motors reached to heat balance status (V/F: Linearity; low speed torque increase 3%):

电机型号 TYPE	频率(Hz) FREQUENCY	输出转矩(NM) OUTPUT TORQUE	输出转速(r/min) OUTPUT SPEED	指示电压(V) VOLTAGE	指示电流(A) CURRENT	电机绕组温升(K) TEMPERATURE RISE
MS7122	17	1.88	649	135	1.2	77.07
MS7124	13	2.46	214	111	1.0	70.48
MS8022	17.5	3.75	776	149	2.2	76.1
MS8024	20	5.12	478	170	1.9	76.8
MS90L-2	20	7.518	1060	174	4.7	79.8
MS90L-4	20	10.23	480	165	3.8	83.6

注：1. V/F：线性；低速转矩提升设置3%

2. 表中电压及电流为变频器指示值

Note: 1, V/F: linearity; with 3% increase to low speed torque
2, the voltage and current in above table are designation data of inverter

轴负荷及旋转精度

Radial load and rotational precise

•输出轴许可径向加载力

电机输出轴中点的许可径向加载力 F_r (N) 与电机的轴承寿命及工作转速有关。以下表格分别列出轴承使用寿命按 20000 小时及 40000 小时计算时的各型电机输出轴的最大许可径向加载力：

Allowed radial load force on output shaft

Allowed radial load force F_r (N) at the mid point of motor output shaft is related with the bearing life and the rotational speed of motor. The Max. allowed radial load force on each size motor output shaft has been listed in following table calculated in accordance with different bearing life of 20000 hours and 40000 hours.

电机规格 MOTOR SIZE	20000 h			40000h		
	2p	4p	6p	2p	4p	6p
71	410	520	600	330	410	470
80	660	840	950	500	660	750
90	720	900	1000	550	720	820
100	1000	1250	1400	790	1000	1100

- F_r 值在各个方向均相同；

-当径向力与轴向力同时施加时,许可的轴向力为径向力的1/5；

- F_r value is the same in every direction.

- Allowed axial force is 1/5 of radial force when they load together.

- F_r 值在各个方向均相同；

-当径向力与轴向力同时施加时,许可的轴向力为径向力的1/5；

- F_r value is the same in every direction.

- Allowed axial force is 1/5 of radial force when they load together.

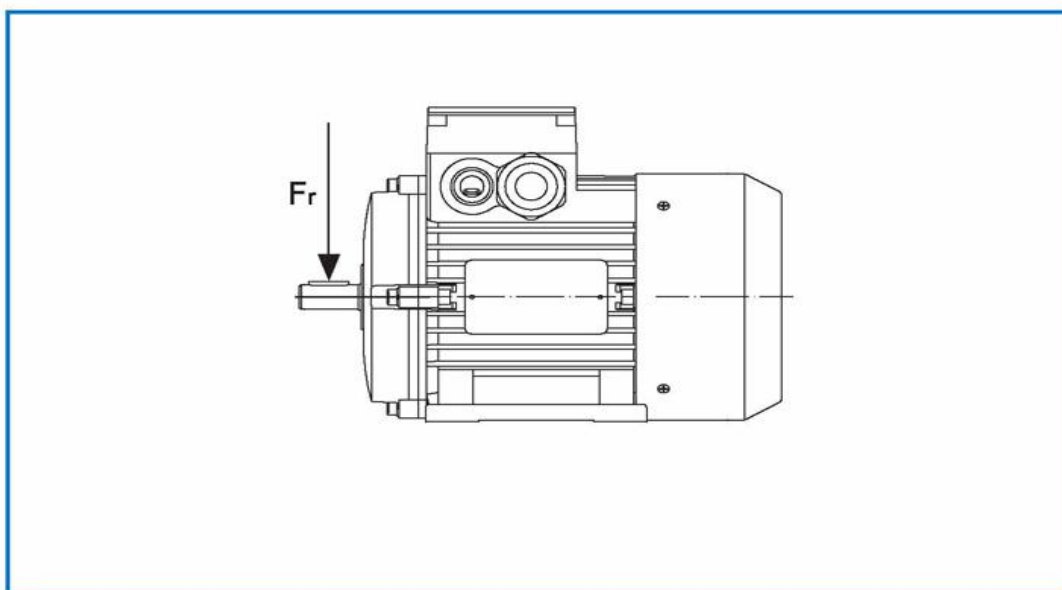

公司名称：上海梁瑾机电设备有限公司

联系人：杨奇 13661695091

QQ:1914222621 570998234

电话:021-37652287 传真:021-57872573

网址：<http://www.zik-rhg.com> www.shhgjdqi.com

地址：中国上海上海市松江区茜浦路 850 弄 33 号

形位精度 / POSITION PRECISION

如下图所示，所有本公司制造的电机轴的旋转跳动值 $<0.02\text{mm}$ ，对于法兰式安装（B5、B14）结构，转轴与法兰定位止口的同轴度 $<0.05\text{mm}$ ，与法兰定位平面的垂直度 $<0.05\text{mm}$ 。

As shown in following pictures, the rotational axial run out on shafts of all electric motors made by our company is less than 0.02mm ; Refer to flange mounting (B5, B14) structure, The axial run out between the rotational shaft and the stop ring of flange is less than 0.05mm , and the vertical run out between shaft and the flange face is less than 0.05mm .

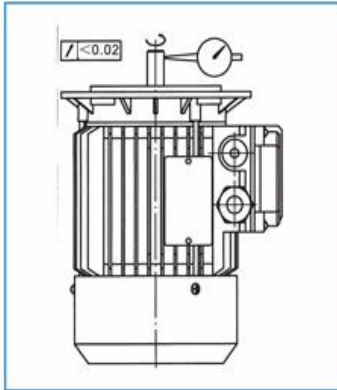

电机轴的旋转跳动值 $<0.02\text{mm}$
Axial run out of shaft $<0.02\text{mm}$

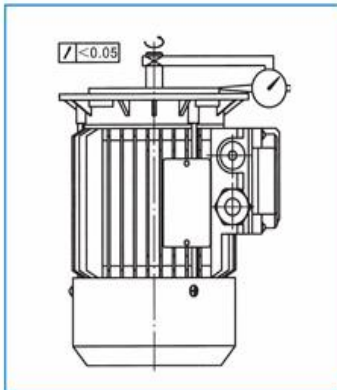

转轴与法兰定位止口的同轴度 $<0.05\text{mm}$
Axial run out of shaft and stop ring of flange $<0.05\text{mm}$

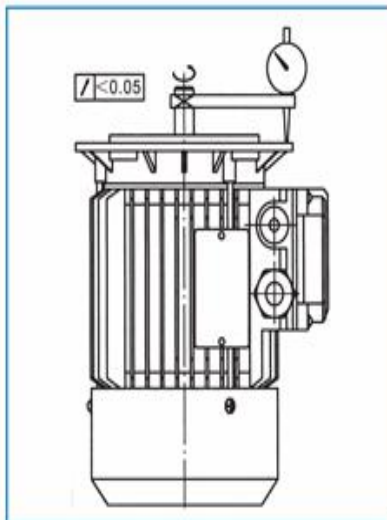

转轴与法兰定位止口的垂直度 $<0.05\text{mm}$
Vertical run out of shaft and flange face $<0.05\text{mm}$

MS三相异步电动机性能参数/MS PERFORMANCE PARAMETER

TYPE	POWER (KW)	N_n (R/MIN)	I_x (A)	$\cos\phi$	M_n (N.M)	M_{tr}/M_n	M_{max}/M_n	I_t/I_n	η (%)
2P $n_0=3000r/min$									
MS5612	0.09	2800	0.32	0.68	0.31	2.3	2.3	6	62
MS5622	0.12	2800	0.38	0.71	0.41	2.3	2.3	6	67
MS6312	0.18	2800	0.53	0.75	0.61	2.3	2.3	6	69
MS6322	0.25	2800	0.68	0.78	0.85	2.3	2.3	6	72
MS7112	0.37	2800	0.96	0.8	1.26	2.3	2.3	6	73.5
MS7122	0.55	2800	1.35	0.82	1.88	2.3	2.3	6	75.5
MS8012	0.75	2800	1.73	0.85	2.56	2.2	2.3	6	77.4
MS8022	1.1	2800	2.47	0.85	3.75	2.2	2.3	7	79.6
MS90S-2	1.5	2840	3.3	0.85	5.04	2.2	2.3	7	81.3
MS90L-2	2.2	2840	4.7	0.86	7.40	2.2	2.3	7	83.2
MS100L-2	3	2860	6.2	0.87	10.0	2.2	2.3	7.5	84.6
MS112M-2	4	2860	8.0	0.88	13.4	2.2	2.3	7.5	85.8
MS132S-2	5.5	2900	10.9	0.88	18.1	2.2	2.3	7.5	87
MS132M-2	7.5	2900	14.7	0.88	24.7	2.2	2.3	7.5	88.1
4P $n_0=1500r/min$									
MS5614	0.06	1380	0.28	0.58	0.42	2.4	2.4	6	56
MS5624	0.09	1380	0.39	0.61	0.62	2.4	2.4	6	58
MS6314	0.12	1380	0.48	0.63	0.83	2.4	2.4	6	60
MS6324	0.18	1380	0.65	0.66	1.25	2.4	2.4	6	64
MS7114	0.25	1400	0.83	0.68	1.71	2.4	2.4	6	67
MS7124	0.37	1400	1.12	0.72	2.52	2.4	2.4	6	69.5
MS8014	0.55	1400	1.56	0.73	3.75	2.4	2.4	6	73.5
MS8024	0.75	1400	1.91	0.75	5.12	2.3	2.4	6	79.6
MS90S-4	1.1	1420	2.6	0.78	7.40	2.3	2.4	6.5	81.4
MS90L-4	1.5	1420	3.5	0.79	10.1	2.3	2.4	6.5	82.8
MS100L1-4	2.2	1420	4.9	0.81	14.8	2.3	2.3	6.5	84.3
MS100L2-4	3	1420	6.5	0.82	20.2	2.3	2.3	7	85.5
MS112M-4	4	1440	8.6	0.82	26.5	2.3	2.3	7	86.6
MS132S-4	5.5	1450	11.5	0.83	36.2	2.3	2.3	7	87.7
MS132M-4	7.5	1450	15.3	0.84	49.4	2.3	2.3	7	88.7
6P									
MS7116	0.18	910	0.76	0.61	1.89	2.0	2.0	5.5	59
MS7126	0.25	910	0.97	0.62	2.62	2.0	2.0	5.5	63
MS8016	0.37	910	1.33	0.62	3.88	2.0	2.0	5.5	68
MS8026	0.55	910	1.84	0.64	5.77	2.0	2.1	5.5	71
MS90S-6	0.75	920	2.2	0.68	7.79	2.0	2.1	5.5	75.9
MS90L-6	1.1	920	3.1	0.7	11.4	2.0	2.1	6	78.1
MS100L-6	1.5	940	3.8	0.75	15.2	2.0	2.1	6	79.8
MS112M-6	2.2	940	5.4	0.76	22.4	2.0	2.1	6.5	81.8
MS132S-6	3	960	7.2	0.76	29.8	2.1	2.1	6.5	83.3
MS132M1-6	4	960	9.5	0.76	39.8	2.1	2.1	6.5	84.6
MS132M2-6	5.5	960	12.6	0.77	54.7	2.1	2.1	6.5	86

MSH高效率三相异步电动机性能参数

MSH HIGH EFFICIENCY THREE PHASE MOTOR PERFORMANCE PARAMETER

TYPE	POWER (KW)	N_n (R/MIN)	I_n (A)	$\cos\phi$	M_n (N.M)	M_{10}/M_n	M_{150}/M_n	I_s/I_n	η (%)
------	------------	---------------	-----------	------------	-------------	--------------	---------------	-----------	------------

2P

$n_0=3000r/min$

MSH8012	0.75	2800	1.66	0.85	2.56	2.2	2.3	6	80.7
MSH8022	1.1	2800	2.38	0.85	3.75	2.2	2.3	7	82.7
MSH90S-2	1.5	2840	3.2	0.85	5.04	2.2	2.3	7	84.2
MSH90L-2	2.2	2840	4.5	0.86	7.40	2.2	2.3	7	85.9
MSH100L-2	3	2860	6.0	0.87	10.0	2.2	2.3	7.5	87.1
MSH112M-2	4	2860	7.8	0.88	13.4	2.2	2.3	7.5	88.1
MSH132S-2	5.5	2900	10.6	0.88	18.1	2.2	2.3	7.5	89.2
MSH132M-2	7.5	2900	14.4	0.88	24.7	2.2	2.3	7.5	90.1

4P

$n_0=1500r/min$

MSH8024	0.75	1400	1.84	0.75	5.12	2.3	2.4	6	82.5
MSH90S-4	1.1	1420	2.5	0.78	7.40	2.3	2.4	6.5	84.1
MSH90L-4	1.5	1420	3.4	0.79	10.1	2.3	2.4	6.5	85.3
MSH100L1-4	2.2	1420	4.8	0.81	14.8	2.3	2.3	6.5	86.7
MSH100L2-4	3	1420	6.3	0.82	20.2	2.3	2.3	7	87.7
MSH112M-4	4	1440	8.4	0.82	26.5	2.3	2.3	7	88.6
MSH132S-4	5.5	1450	12.0	0.83	36.2	2.3	2.3	7	83.6
MSH132M-4	7.5	1450	15.0	0.84	49.4	2.3	2.3	7	90.4

6P

$n_0=1000r/min$

MSH90S-6	0.75	920	2.1	0.68	7.79	2.0	2.1	5.5	78.9
MSH90L-6	1.1	920	2.9	0.7	11.4	2.0	2.1	6	81
MSH100L-6	1.5	940	3.7	0.75	15.2	2.0	2.1	6	82.5
MSH112M-6	2.2	940	5.2	0.76	22.4	2.0	2.1	6.5	84.3
MSH132S-6	3	960	7.0	0.76	29.8	2.1	2.1	6.5	85.6
MSH132M1-6	4	960	9.2	0.76	39.8	2.1	2.1	6.5	86.8
MSH132M2-6	5.5	960	12.3	0.77	54.7	2.1	2.1	6.5	88

注：以上参数按三相380V/50Hz的额定电压及频率提供。

Note: the above parameters are under condition: 3 phases 380V/50Hz

公司名称：上海梁瑾机电设备有限公司

联系人：杨奇 13661695091

QQ:1914222621 570998234





电话:021-37652287 传真:021-57872573

网址：<http://www.zik-rhg.com> www.shhgjdqi.com

地址：中国上海上海市松江区茜浦路 850 弄 33 号

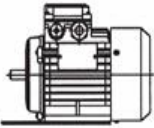
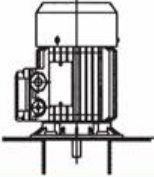
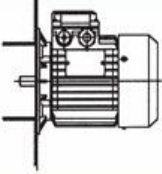
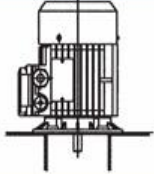
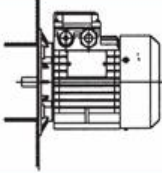
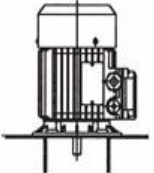
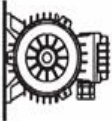
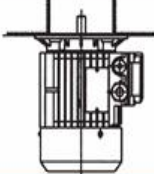
电机结构安装型式符合GB997; IEC 60034-7标准。

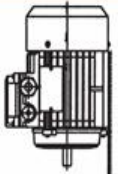
Electric structure mounting position is in accordance with GB997 and IEC60034-7standard.

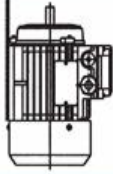
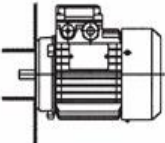
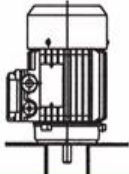
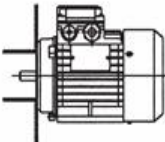
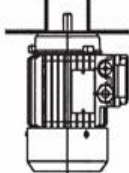
 <p>B3 IM 1001</p>	 <p>V1 IM 3011</p>
 <p>B5 IM 3001</p>	 <p>V1/V5 IM 2011</p>
 <p>B3/B5 IM 2001</p>	 <p>V3 IM 3031</p>
 <p>B6 IM 1051</p>	 <p>V3/V6 IM 2031</p>
 <p>B7 IM 1061</p>	 <p>V5 IM 1011</p>
 <p>B8 IM 1071</p>	 <p>V6 IM 1031</p>
 <p>B14 IM 3601</p>	 <p>V18 IM 3611</p>
 <p>B3/B14 IM 2101</p>	 <p>V19 IM 3631</p>

MS(H)56尺寸/MS(H)56 DIMENSIONS

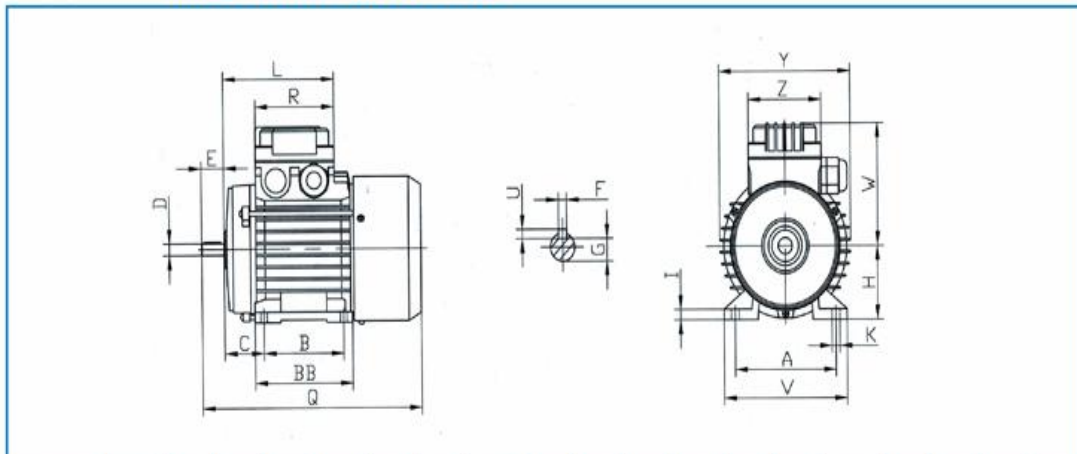

MS(H)56	90	71	35	9	20	3	7.2	56	8	195	3	110	93	117	87	99	70	65	5.8
-B3-	A	B	C	D	E	F	G	H	I	Q	U	V	W	Y	BB	L	R	Z	K

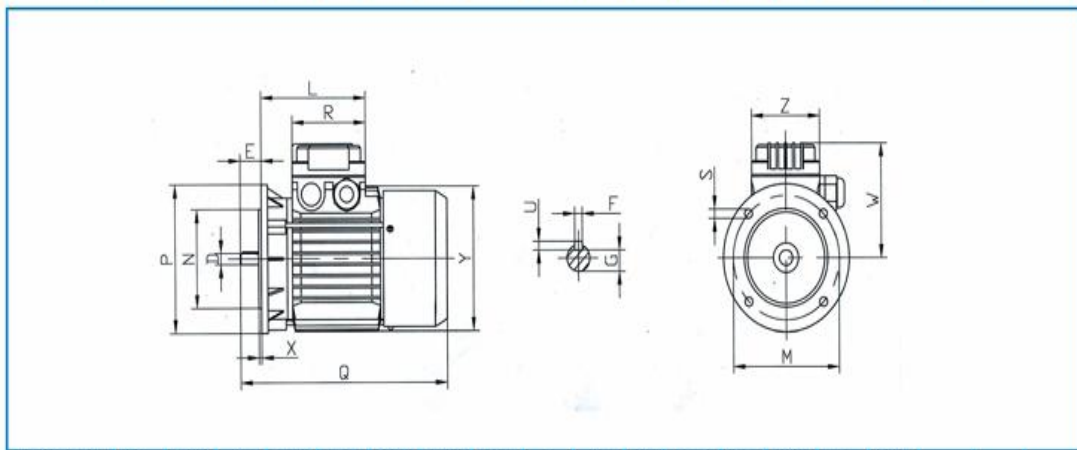

MS(H)56	9	20	3	7.2	100	80	120	197	7	3	93	2.5	117	100	70	65			
-B5-	D	E	F	G	M	N	P	Q	S	U	W	X	Y	L	R	Z			

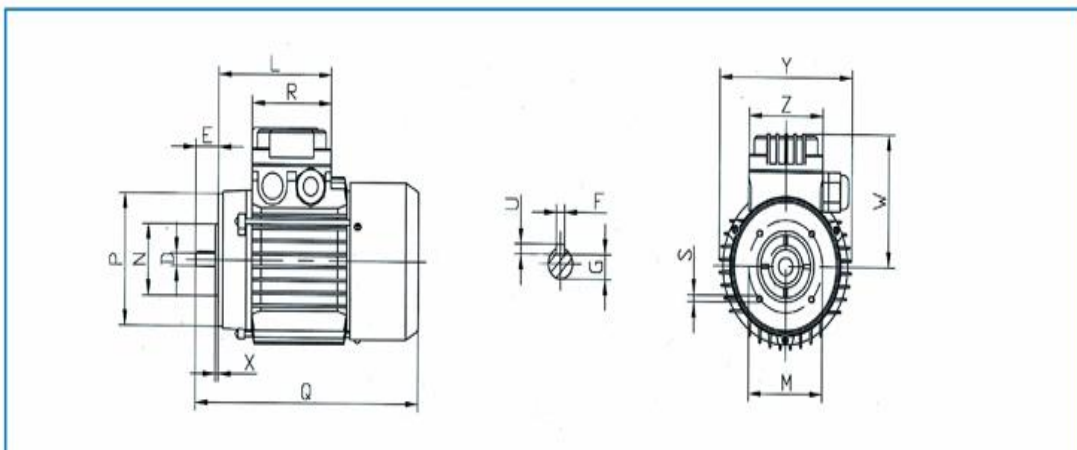

MS(H)56	9	20	3	7.2	65	50	80	197	M5	3	93	2.5	117	100	70	65			
-B14-	D	E	F	G	M	N	P	Q	S	U	W	X	Y	L	R	Z			

MS(H)63尺寸/MS(H)63 DIMENSIONS

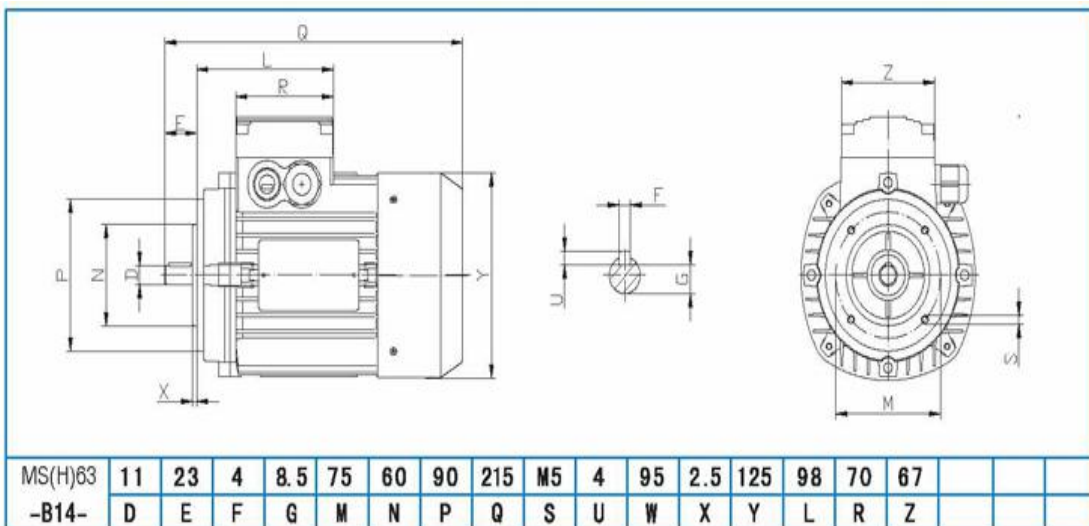
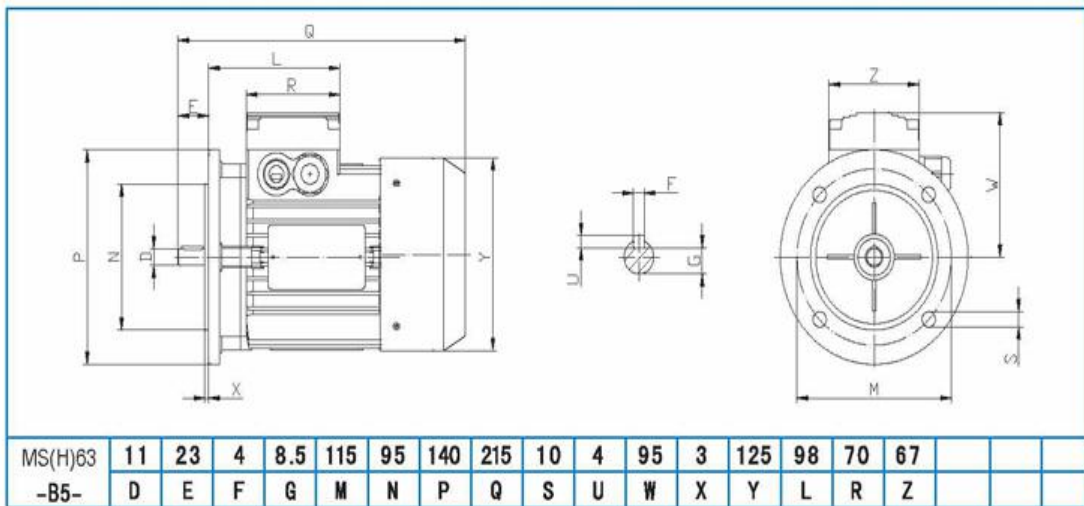
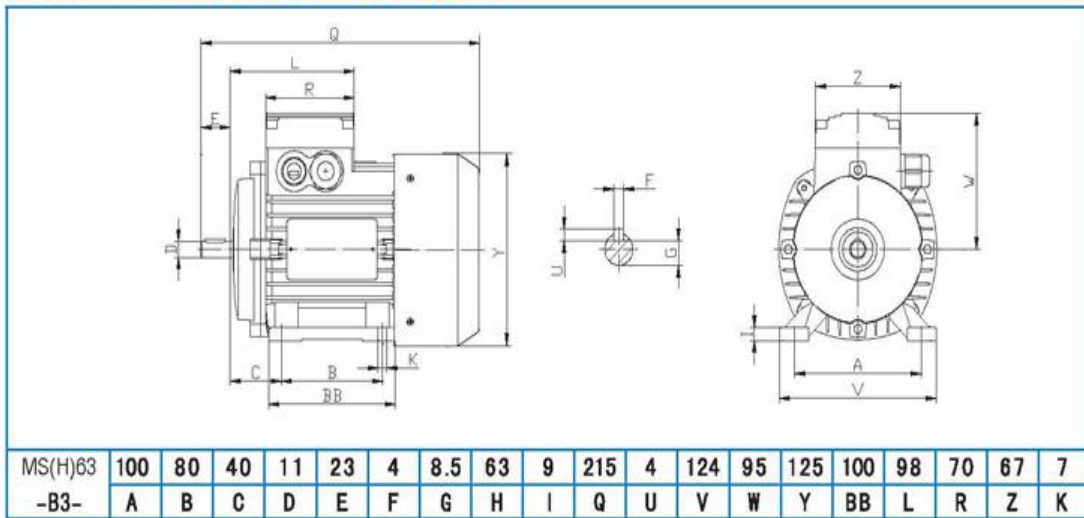

MS(H)71尺寸/MS(H)71 DIMENSIONS

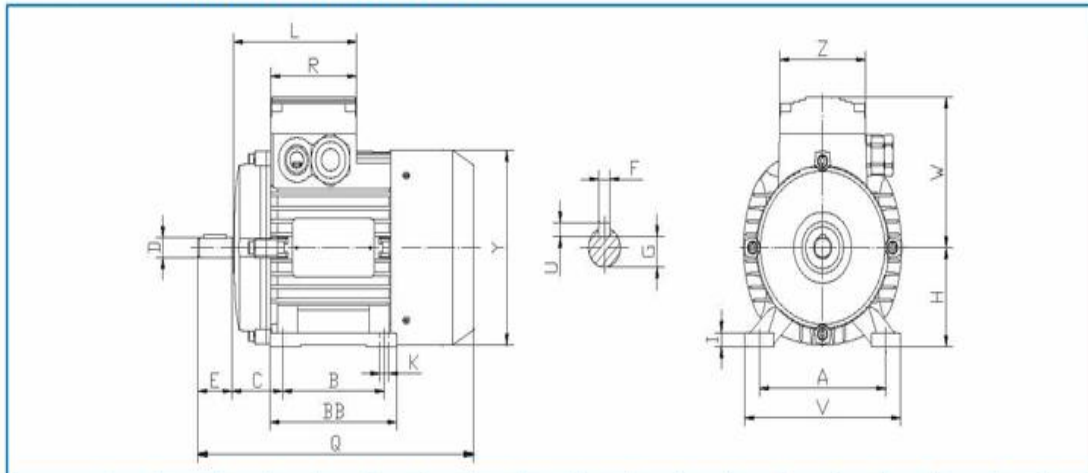

MS(H)71	112	90	45	14	30	5	11	71	10	245	5	136	108	140	113	114	76	76	7
-B3-	A	B	C	D	E	F	G	H	I	Q	U	V	W	Y	BB	L	R	Z	K

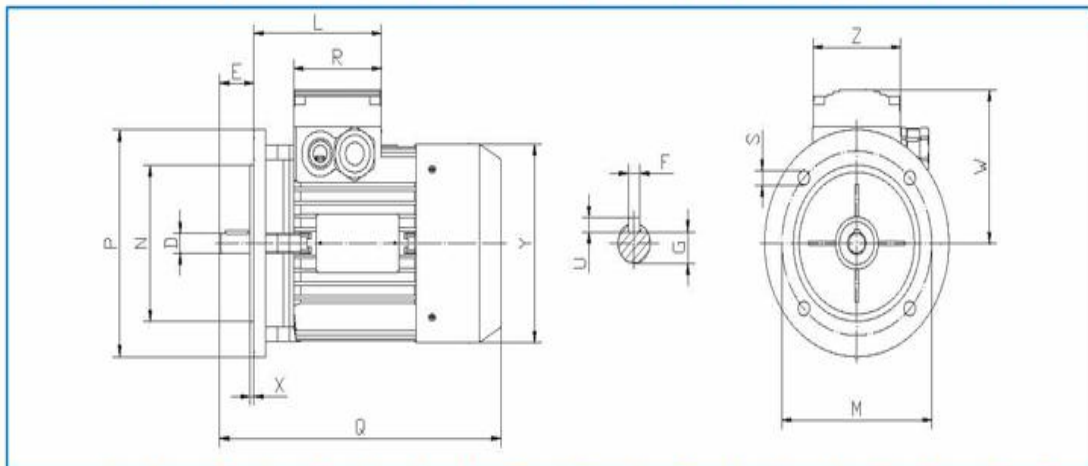

MS(H)71	14	30	5	11	130	110	160	245	10	5	108	3.5	140	108	76	76			
-B5-	D	E	F	G	M	N	P	Q	S	U	W	X	Y	L	R	Z			

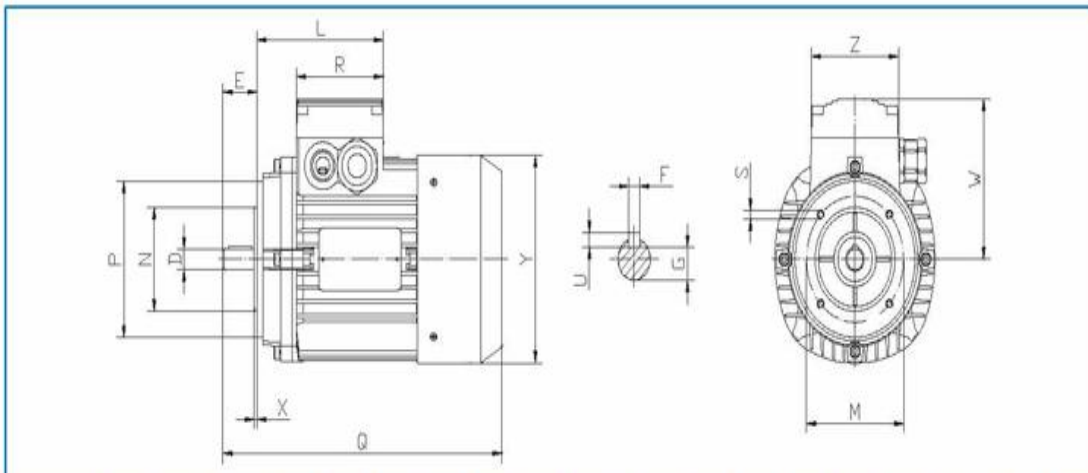

MS(H)71	14	30	5	11	85	70	105	245	M6	5	108	2.5	140	114	76	76			
-B14-	D	E	F	G	M	N	P	Q	S	U	W	X	Y	L	R	Z			

MS(H)80尺寸/MS(H)80 DIMENSIONS

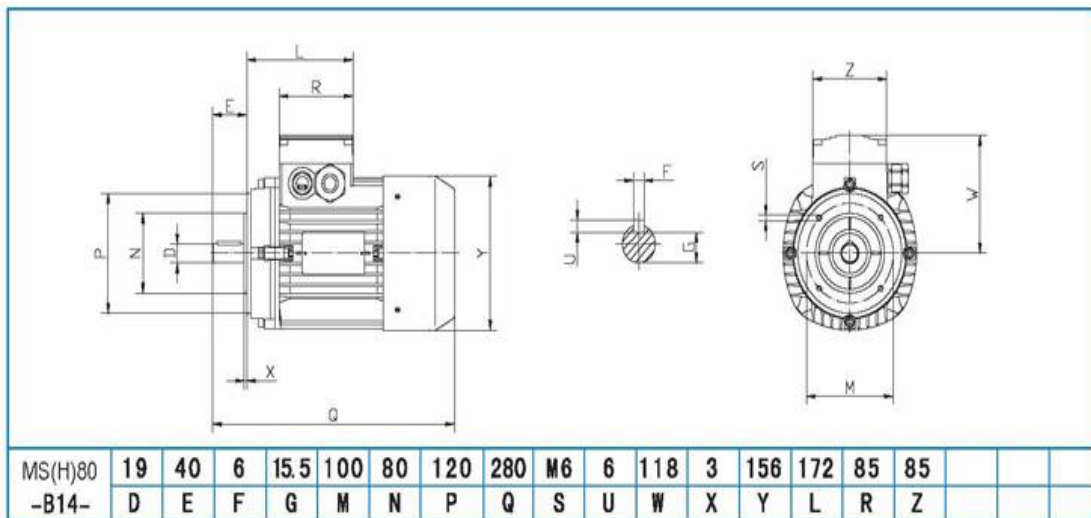
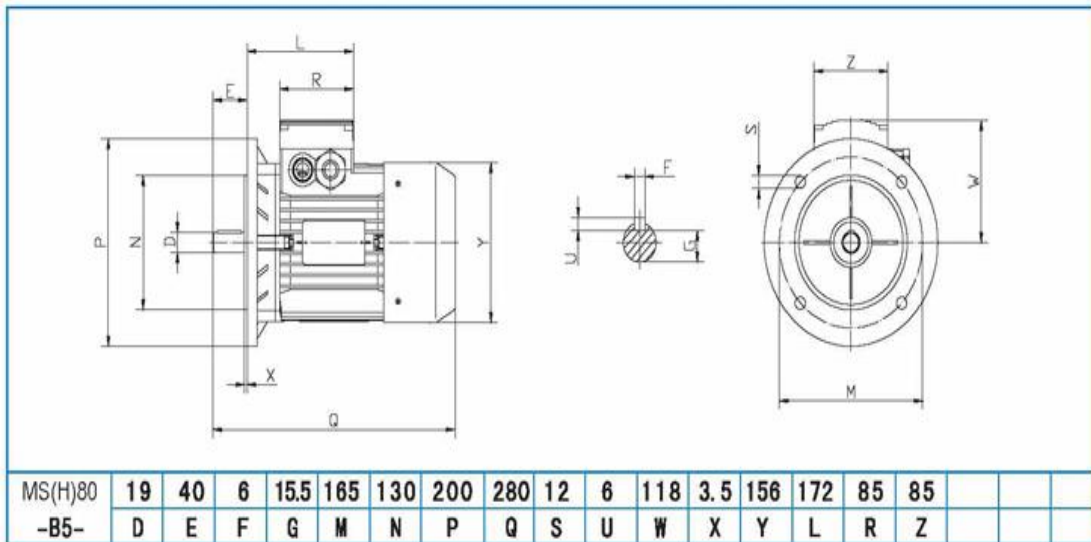
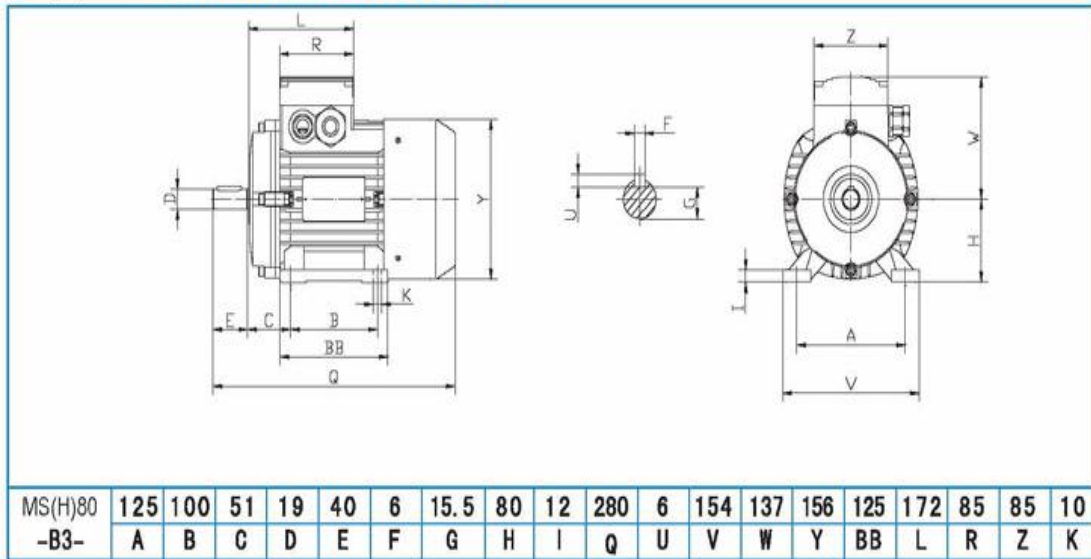

MS(H)90S尺寸/MS(H)90S DIMENSIONS

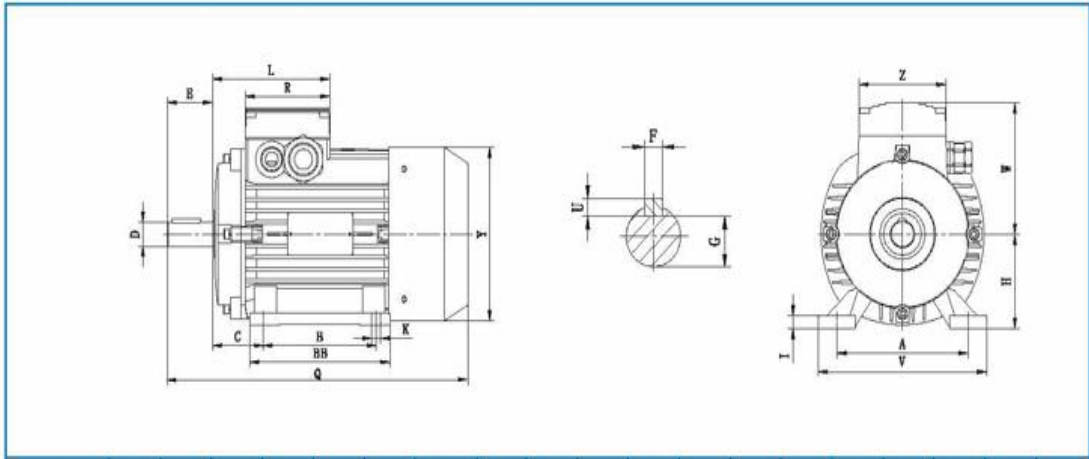

MS(H)90S	140	100	56	24	50	8	20	90	12	312	7	180	125	174	130	130	93	93	10
-B3-	A	B	C	D	E	F	G	H	I	Q	U	V	W	Y	BB	L	R	Z	K

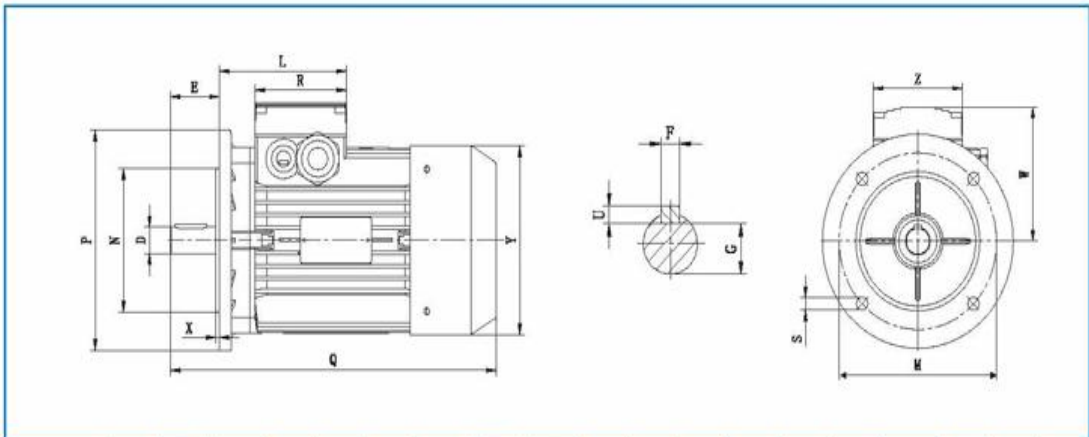

MS(H)90S	24	50	8	20	165	130	200	312	12	7	125	3.5	174	130	93	93			
-B5-	D	E	F	G	M	N	P	Q	S	U	W	X	Y	L	R	Z			

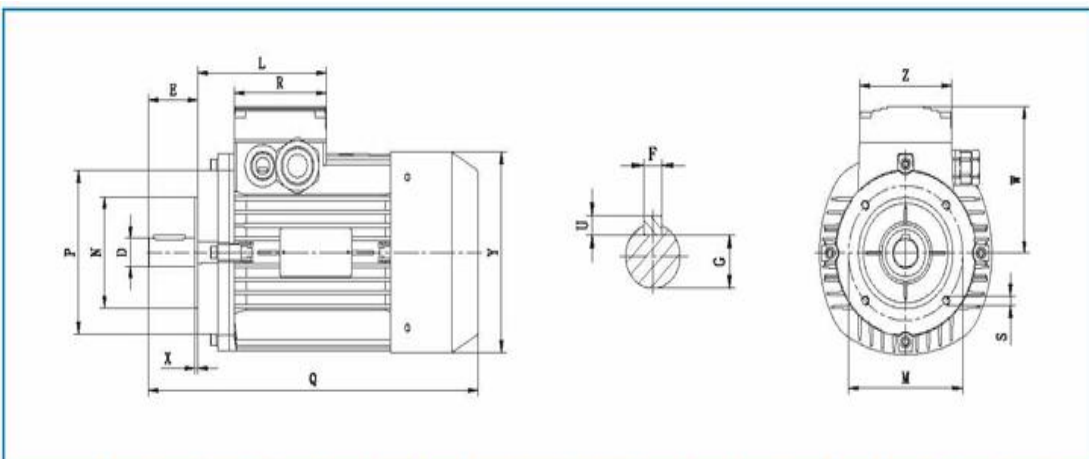

MS(H)90S	24	50	8	20	115	95	138	336	M8	7	125	3	174	130	93	93			
-B14-	D	E	F	G	M	N	P	Q	S	U	W	X	Y	L	R	Z			

MS(H)90L尺寸/MS(H)90L DIMENSIONS

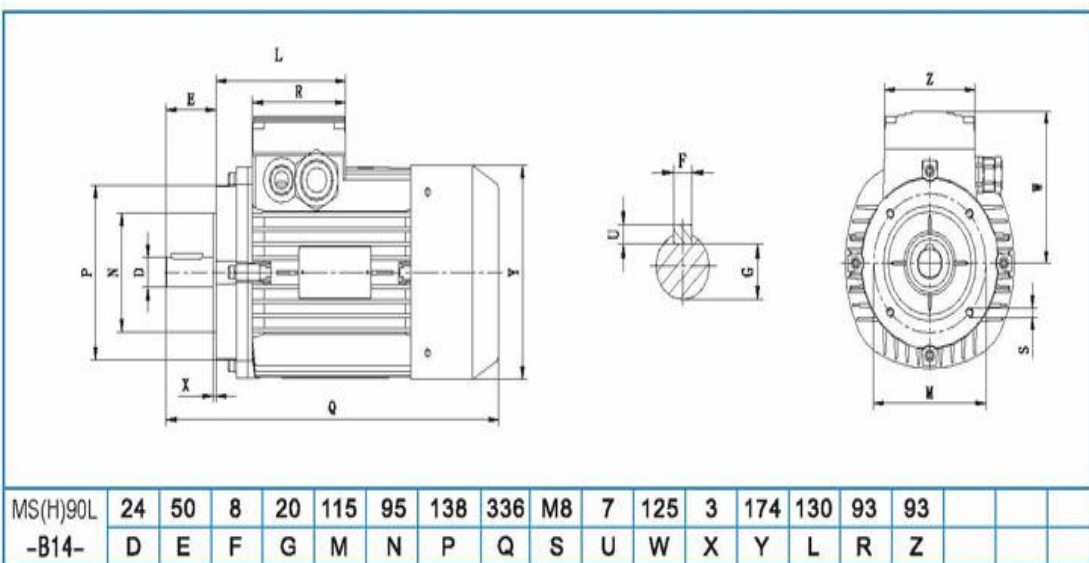
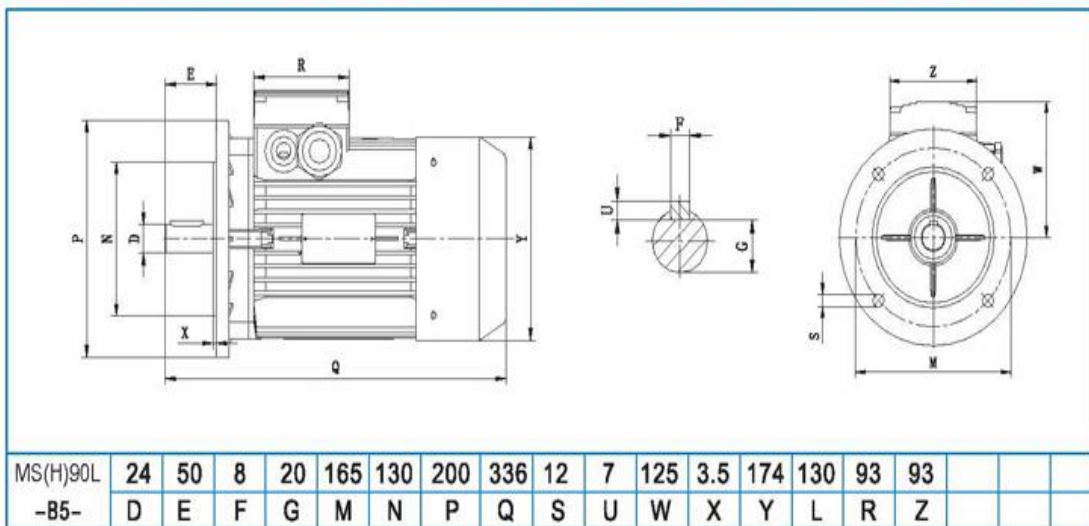
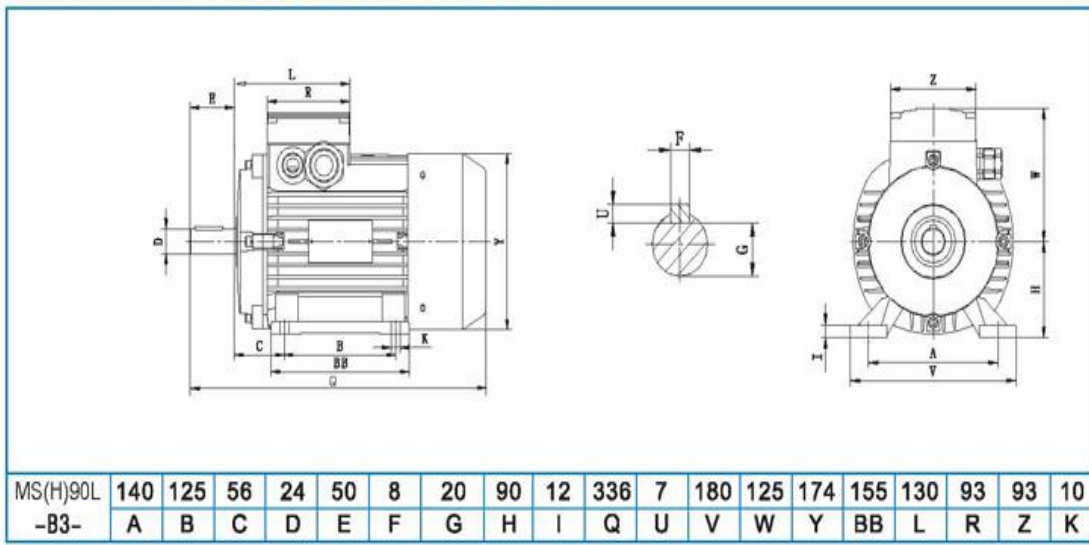

MS(H)100L尺寸/MS(H)100L DIMENSIONS

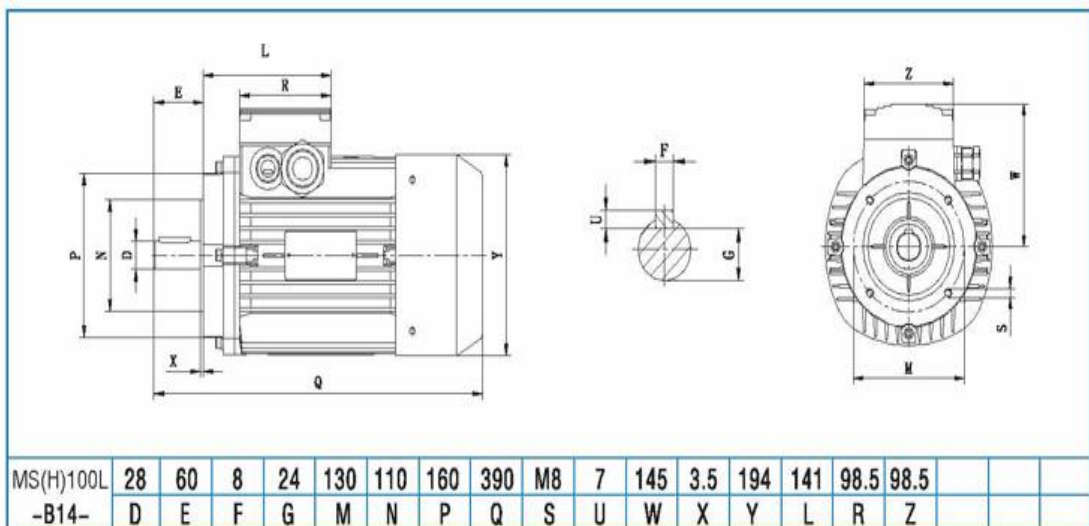
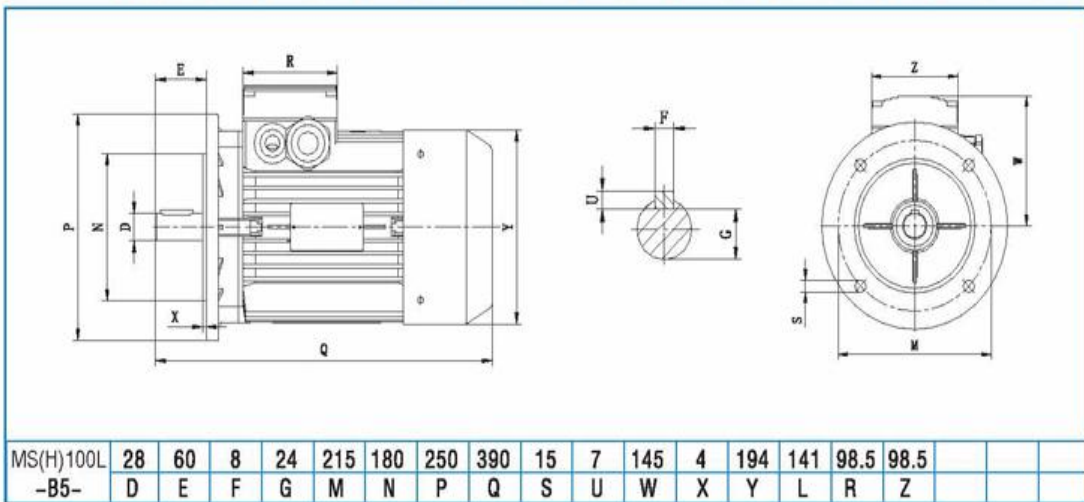
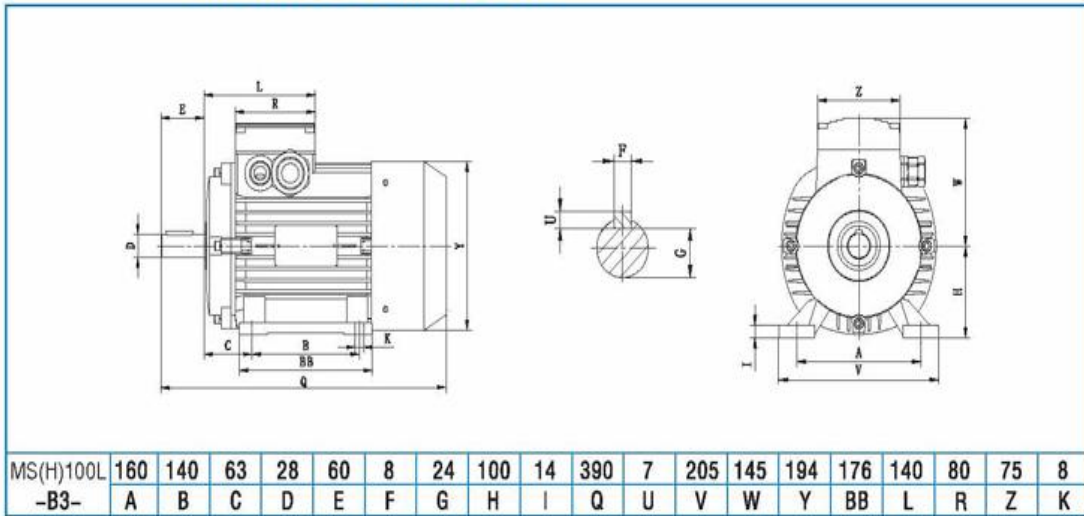

MS(H)112M尺寸/MS(H)112M DIMENSIONS

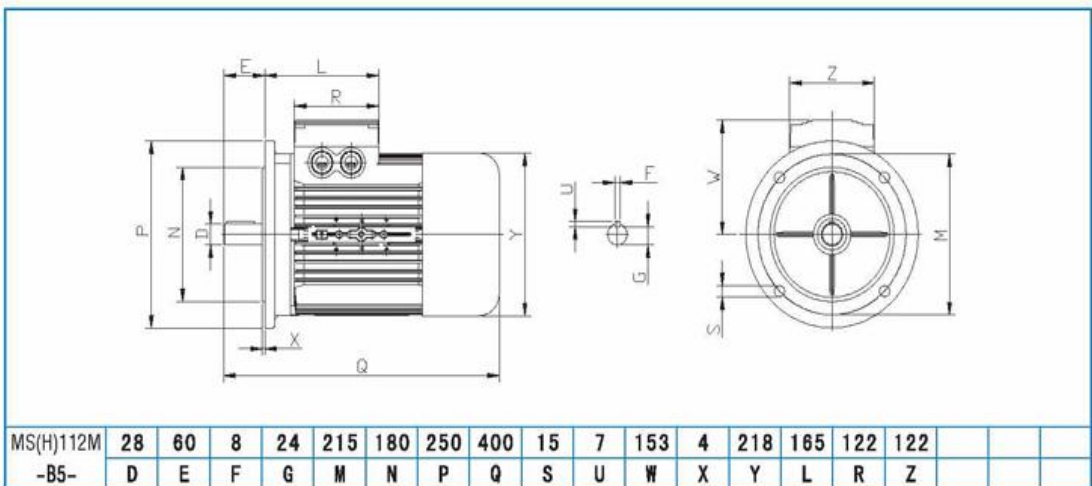
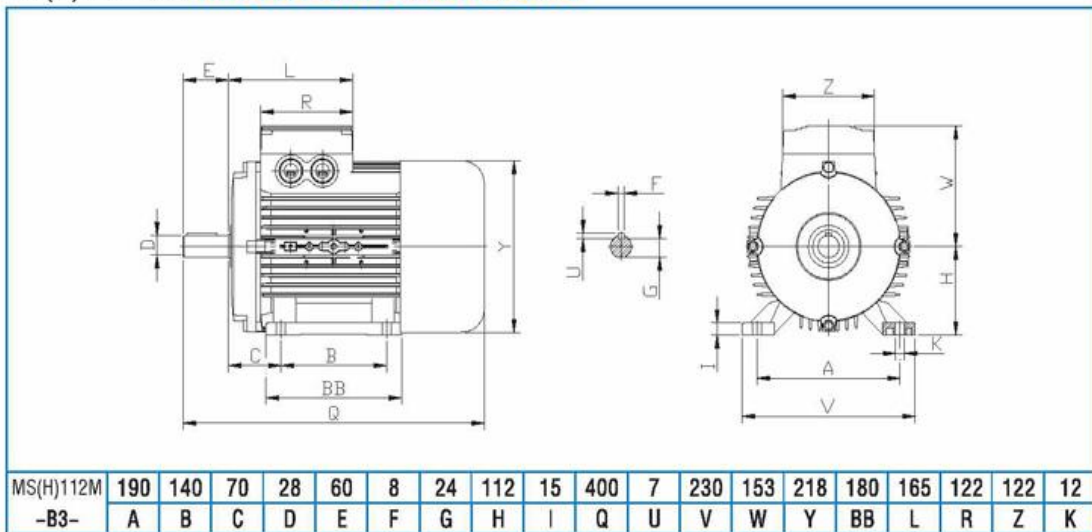

公司名称：上海梁瑾机电设备有限公司
 联系人：杨奇 13661695091
 QQ:1914222621 570998234
 电话:021-37652287 传真:021-57872573
 网址: <http://www.zik-rhg.com> www.shhgjdqi.com
 地址：中国上海上海市松江区茜浦路 850 弄 33 号

MS(H)132S尺寸/MS(H)132S DIMENSIONS

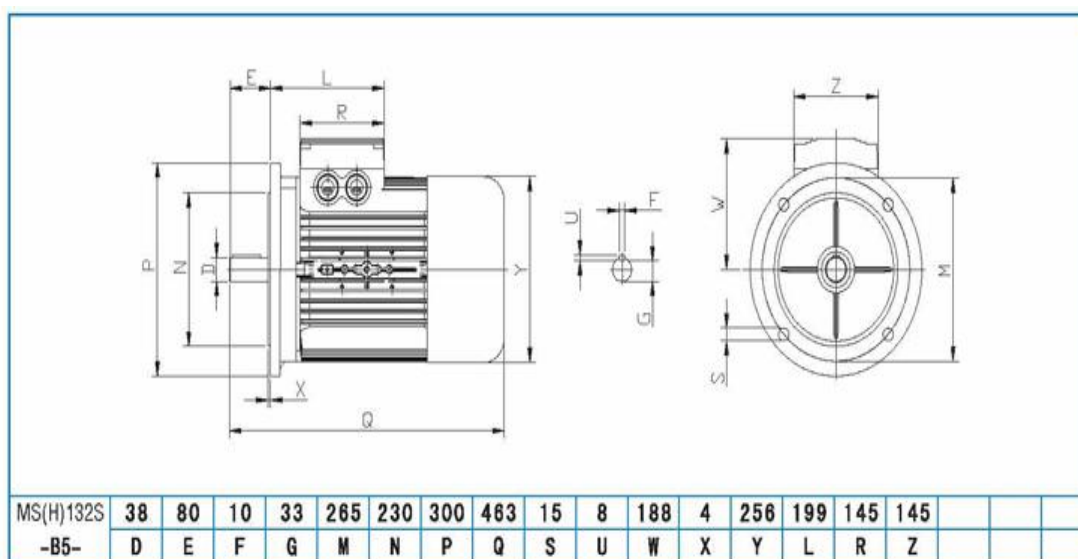
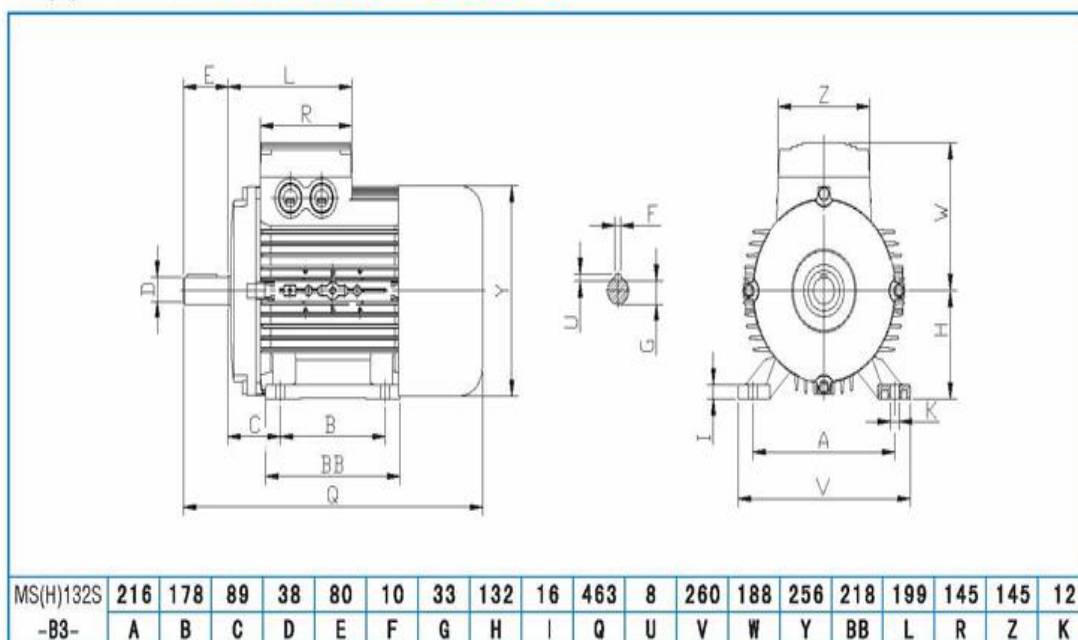

公司名称：上海梁瑾机电设备有限公司

联系人：杨奇 13661695091

QQ:1914222621 570998234

电话:021-37652287 传真:021-57872573

网址: <http://www.zik-rhg.com> www.shhgjdqi.com

地址：中国上海上海市松江区茜浦路 850 弄 33 号

MS(H)132M尺寸/MS(H)132M DIMENSIONS

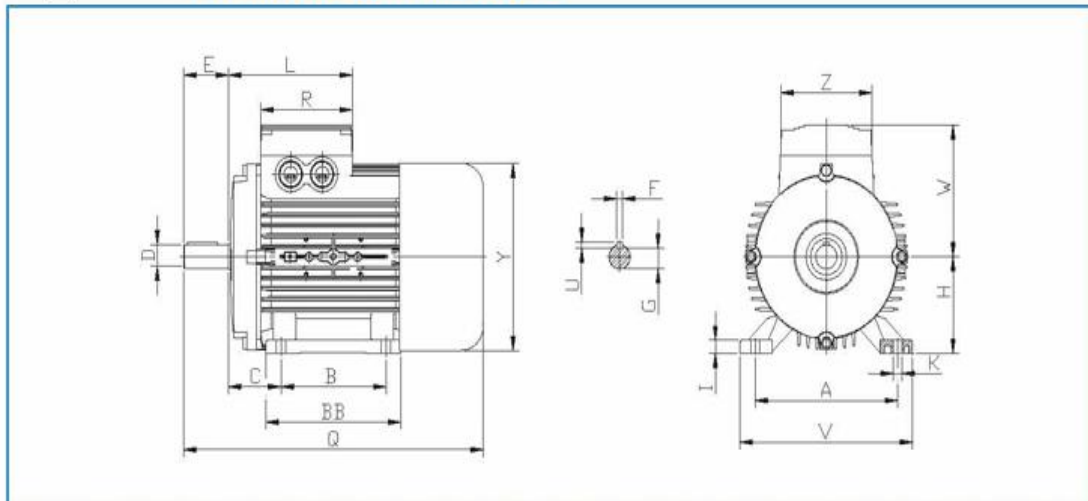

MS(H)132M	216	215	89	38	80	10	33	132	16	500	8	260	188	256	255	199	145	145	12
-B3-	A	B	C	D	E	F	G	H	I	Q	U	V	W	Y	BB	L	R	Z	K

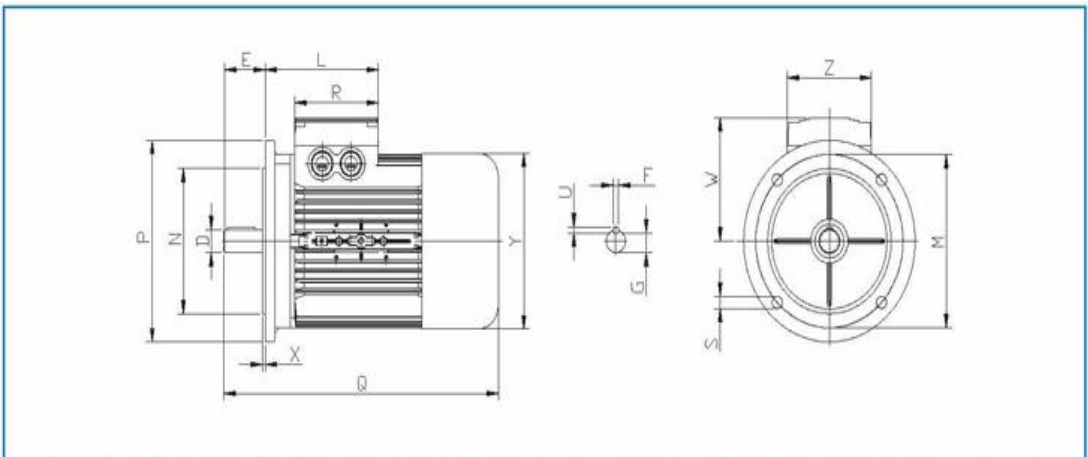

MS(H)132M	38	80	10	33	265	230	300	500	15	8	188	4	256	199	145	145			
-B5-	D	E	F	G	M	N	P	Q	S	U	W	X	Y	L	R	Z			

公司名称: 上海梁瑾机电设备有限公司
 联系人: 杨奇 13661695091
 QQ:1914222621 570998234
 电话:021-37652287 传真:021-57872573
 网址: <http://www.zik-rhg.com> www.shhgjdqi.com
 地址: 中国上海上海市松江区茜浦路 850 弄 33 号

接线示意图 / CONNECTION DIAGRAM

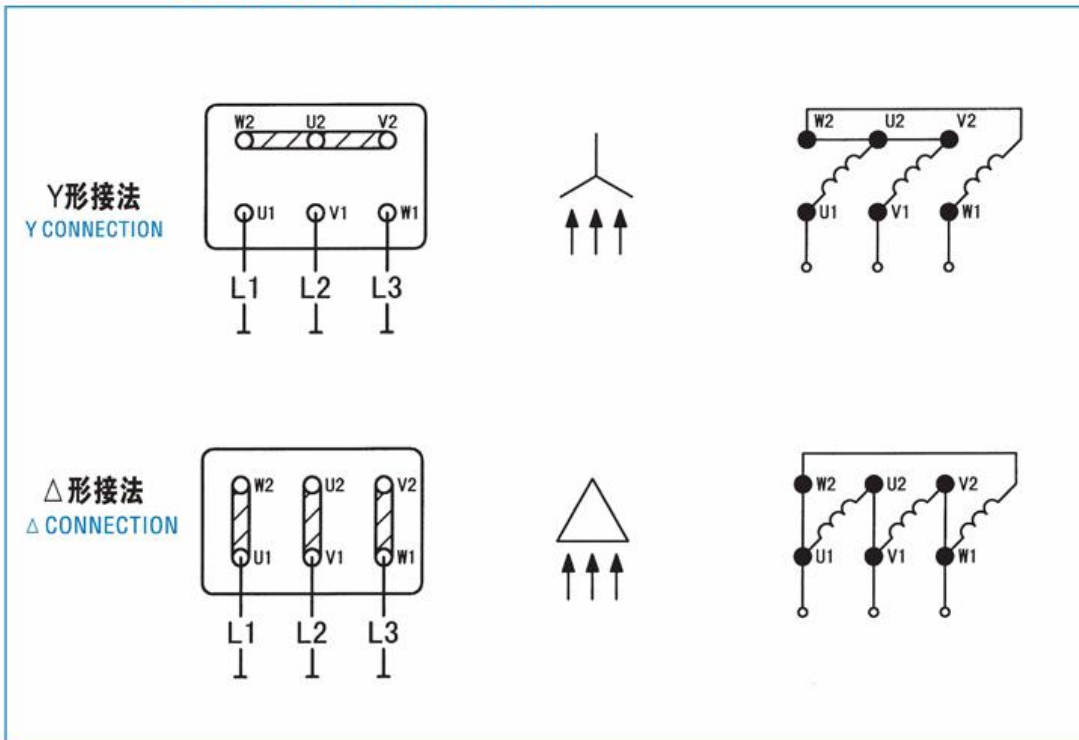

电机选型 / MOTOR SELECTION

1. 选定电机转速

根据负载的要求选定电机的极数，考虑以下原则：

- ◆ 尽量考虑直接传动，只有当电机的转速难以符合机械要求时，才考虑采用变速传动装置；
- ◆ 考虑传动变速装置时，应使电机的转速适宜最小的传动级数，以达到最高的传动效率；
- ◆ 采用变频调速时，应使电机的额定转速最接近使用转速。

1. Select the rotation speed of the motor

Referring to following principle to select the poles of the motor according to the requirement of load. Try to select direct drive. Only when rotation speed could not meet the mechanical requirement, the variable speed drive will be applied to. When the variable speed drive is applied, try to have the rotation speed match the min. transmission poles to have the max. transmission efficiency. When the frequency control is applied, the rate rotate speed should be very closed to the normal speed.

2. 按以下流程选定电机容量

2. Select the capacity of the motor according as per the following process.

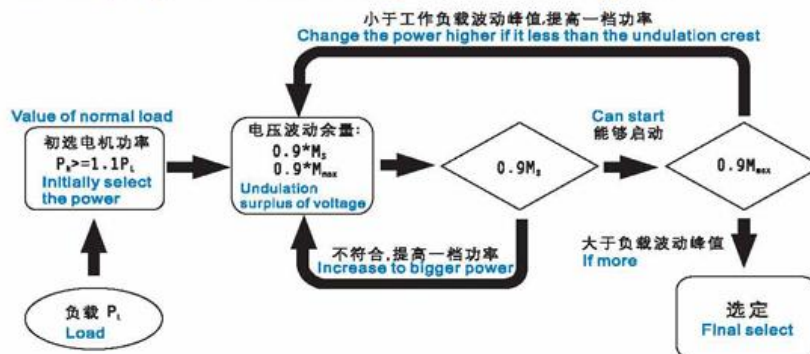

3. 选定安装型式

参照A20页电机安装方式，选定电机的结构安装型式。

3. Select the mounting form: According to the form on page A20.

4. 校验电机的安装空间

参照尺寸表中该型电机的具体尺寸，校核电机在工作机械中是否与别的部件相干涉，是否留有足够的冷却散热空间。

4. Check the mounting space of motor: Referring to the sizes sheet of motor measurement, check if there is some other mechanical structure related with and there is enough room for cooling.

5. 外壳防护等级及绝缘等级指定

如电机使用环境无水或偶然有溅水，可考虑采用IP54；如使用环境有雨水等考虑采用IP55。一般用途可采用B级绝缘，如配置变频器推荐采用F级。

5. Confirm the protection and insulation classes of the outside shell: if there is no water or only some spatter water in the operation environment, IP54 is recommended; if there is water in the environment, IP55 will be the best. For the insulation classes, B class is applied for general use. If there is the inverter, F class is recommended.

订货须知 /NOTICE FOR ORDER

用户在订购本公司电机产品时，须向本公司说明以下各项的产品信息：

1. 电机型号

2. 安装型式

3. 电机额定工作电压及频率。如有指定，将按客户要求制作；如无指定，本公司将按三相380V/50Hz的默认标准提供。

4. 外壳喷涂色别。如无指明，本公司将按默认蓝色提供。

5. 外壳防护等级。如有指定可按IP55制作，如无指定将按默认的IP54提供。

6. 绕组绝缘等级。如有指定可按F级制作，如无指定将按默认的B级制作。

When the purchasers order our motors, they should supply the following information to us:

1. Model of motor

2. Mounting position

3. The rated operation voltage and frequency. (if no special requirement, we will supply the motor at 380V/50Hz, 3 phases or 220V/50Hz, single phase.)

4. The paint color of the outside shell (if no special requirement, our color is blue.)

5. Protection classes of the outside shell: IP55 or IP54 (our standard)

6. Insulation classes of the coil: B class or F class..

